

BLOWTAC

ROOTS BLOWER

魯式鼓風機



THREE LOBES ROOTS BLOWER REDUCE VIBRATION AND NOISE!

■ LOWER ENERGY CONSUMPTION

Three lobes' design control backflow pressure to rotor so reduce energy consumption.

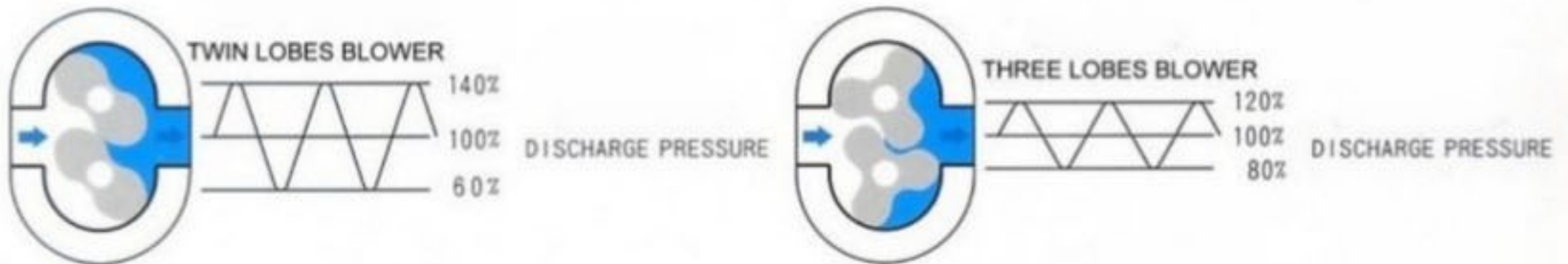

■ LOWER NOISE

Pressure pluses are the major noise source of blower. Three lobes' design can efficiently reduce noise by approximately 5dB.

■ LONGER BEARING LIFE

Less vibration transmitted through the lobe results approximately 20% longer bearing life.

Conventional blowers result pressure pluses and vibration rob power and shorten the life of every bearing, gear and other drive train components.

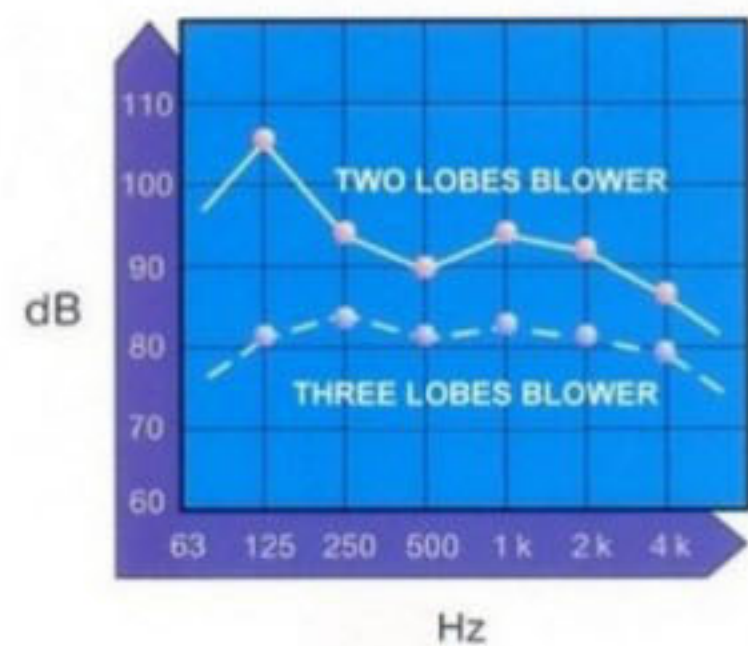

FEATURE

- ◆ Wide range for air volume, pressure and vacuum.
 1. Bore : 40A ~ 400A (1.5" ~ 16")
 2. Capacity : 0.5 ~ 360 m³/min
 3. Pressure : 0 ~ 8000 mmAq
 4. Vacuum : - 5000 mmAq
- ◆ Stable air flow and less pressure variation.
- ◆ Clean air without oil moist.
- ◆ Construction simple and easy maintenance.
- ◆ Bearings are completely lubricated by oil moist.

MRT TYPE PERFORMANCE TABLE (PRESSURE Types)

TYPE	RPM	Qs(m ³ /min)				PRESSURE(mmAq)								La(kW)			
		1000		2000		3000		4000		5000		6000		7000		8000	
		Qs	La	Qs	La	Qs	La	Qs	La	Qs	La	Qs	La	Qs	La	Qs	La
MRT-040	1650	0.60	0.19	0.57	0.37	0.54	0.53	0.51	0.67	0.49	0.81	0.48	0.94				
	1800	0.68	0.21	0.64	0.40	0.61	0.57	0.59	0.74	0.57	0.88	0.55	1.02				
	1950	0.75	0.23	0.71	0.43	0.69	0.62	0.66	0.80	0.64	0.96	0.62	1.11				
	2100	0.83	0.24	0.79	0.47	0.76	0.67	0.74	0.86	0.71	1.03	0.70	1.19				
	2250	0.90	0.26	0.86	0.50	0.84	0.72	0.81	0.92	0.79	1.11	0.77	1.28				
	2400	0.97	0.28	0.94	0.53	0.91	0.77	0.88	0.98	0.86	1.18	0.85	1.36				
	2550	1.05	0.30	1.01	0.57	0.98	0.81	0.96	1.04	0.94	1.25	0.92	1.45				
MRT-050	850	0.99	0.41	0.79	0.80	0.64	1.16	0.50	1.51	0.38	1.84	0.29	2.15	0.21	2.45	0.15	2.74
	1000	1.31	0.48	1.11	0.94	0.96	1.37	0.82	1.77	0.70	2.16	0.61	2.53	0.53	2.88	0.47	3.22
	1150	1.63	0.56	1.44	1.08	1.28	1.57	1.15	2.04	1.02	2.49	0.93	2.91	0.86	3.32	0.79	3.71
	1300	1.95	0.63	1.76	1.22	1.61	1.78	1.47	2.31	1.34	2.81	1.25	3.29	1.18	3.75	1.12	4.19
	1450	2.27	0.70	2.08	1.36	1.93	1.98	1.79	2.57	1.67	3.13	1.58	3.67	1.50	4.18	1.44	4.67
	1600	2.60	0.77	2.40	1.50	2.25	2.19	2.11	2.84	1.99	3.46	1.90	4.05	1.82	4.61	1.76	5.16
	1750	2.92	0.85	2.72	1.64	2.57	2.39	2.43	3.11	2.31	3.78	2.22	4.43	2.14	5.05	2.08	5.64
MRT-065	850	2.07	0.62	1.89	1.21	1.71	1.76	1.55	2.29	1.41	2.78	1.29	3.26	1.19	3.71	1.09	4.15
	1000	2.58	0.73	2.41	1.42	2.22	2.07	2.07	2.69	1.93	3.27	1.81	3.83	1.71	4.37	1.60	4.88
	1150	3.10	0.84	2.93	1.64	2.74	2.38	2.58	3.09	2.45	3.77	2.33	4.41	2.22	5.03	2.12	5.62
	1300	3.62	0.95	3.45	1.85	3.26	2.69	3.10	3.50	2.96	4.26	2.84	4.99	2.74	5.68	2.64	6.35
	1450	4.13	1.06	3.96	2.06	3.77	3.01	3.62	3.90	3.48	4.75	3.36	5.56	3.26	6.34	3.15	7.08
	1600	4.65	1.17	4.48	2.28	4.29	3.32	4.13	4.30	4.00	5.24	3.88	6.14	3.77	6.99	3.67	7.81
	1750	5.17	1.28	5.00	2.49	4.81	3.63	4.65	4.71	4.51	5.73	4.39	6.71	4.29	7.65	4.19	8.55
MRT-080	850	3.24	1.12	2.87	2.14	2.54	3.08	2.23	3.94	1.95	4.73	1.70	5.47	1.48	6.15	1.28	6.79
	1000	4.14	1.32	3.77	2.52	3.44	3.62	3.13	4.63	2.85	5.57	2.60	6.44	2.38	7.24	2.18	7.99
	1150	5.04	1.51	4.67	2.90	4.34	4.16	4.03	5.33	3.75	6.40	3.50	7.40	3.28	8.33	3.08	9.19
	1300	5.94	1.71	5.57	3.27	5.24	4.71	4.93	6.02	4.65	7.24	4.40	8.37	4.18	9.41	3.98	10.39
	1450	6.84	1.91	6.47	3.65	6.14	5.25	5.83	6.72	5.55	8.07	5.30	9.33	5.08	10.50	4.88	11.58
	1600	7.74	2.11	7.37	4.03	7.04	5.79	6.73	7.41	6.45	8.91	6.20	10.30	5.98	11.58	5.78	12.78
	1750	8.64	2.30	8.27	4.41	7.94	6.33	7.63	8.11	7.35	9.75	7.10	11.26	6.88	12.67	6.68	13.98
MRT-100	850	5.80	1.57	5.19	3.00	4.65	4.31	4.16	5.51	3.74	6.63	3.36	7.66	3.03	8.62	2.74	9.51
	1000	7.06	1.84	6.45	3.53	5.91	5.07	5.42	6.49	5.00	7.80	4.62	9.01	4.29	10.14	4.00	11.19
	1150	8.32	2.12	7.71	4.05	7.17	5.83	6.68	7.46	6.26	8.97	5.88	10.36	5.55	11.66	5.26	12.86
	1300	9.58	2.40	8.97	4.58	8.43	6.59	7.94	8.43	7.52	10.14	7.14	11.71	6.81	13.18	6.52	14.54
	1450	10.84	2.67	10.23	5.11	9.69	7.35	9.20	9.41	8.78	11.31	8.40	13.06	8.07	14.70	7.78	16.22
	1600	12.10	2.95	11.49	5.64	10.95	8.11	10.46	10.38	10.04	12.47	9.66	14.42	9.33	16.22	9.04	17.90
	1750	13.36	3.23	12.75	6.17	12.21	8.87	11.72	11.35	11.30	13.64	10.92	15.77	10.59	17.74	10.30	19.57

MRT-125S	750	8.13	2.05	7.43	3.91	6.80	5.62	6.22	7.20	5.72	8.66	5.25	10.01	4.83	11.26	4.46	12.42
	900	10.02	2.46	9.32	4.70	8.69	6.75	8.11	8.64	7.61	10.39	7.14	12.01	6.72	13.51	6.35	14.91
	1050	11.91	2.86	11.21	5.48	10.58	7.87	10.00	10.08	9.50	12.12	9.03	14.01	8.61	15.76	8.24	17.39
	1200	13.80	3.27	13.10	6.26	12.47	9.00	11.89	11.52	11.39	13.85	10.92	16.01	10.50	18.01	10.13	19.88
	1350	15.69	3.68	14.99	7.04	14.36	10.12	13.78	12.96	13.28	15.58	12.81	18.01	12.39	20.27	12.02	22.36
	1500	17.58	4.09	16.88	7.83	16.25	11.25	15.67	14.40	15.17	17.31	14.70	20.01	14.28	22.52	13.91	24.85
	1650	19.47	4.50	18.77	8.61	18.14	12.37	17.56	15.84	17.06	19.04	16.59	22.01	16.17	24.77	15.80	27.33
MRT-125	750	10.29	2.59	9.42	4.96	8.62	7.13	7.88	9.12	7.25	10.97	6.66	12.67	6.11	14.26	5.65	15.74
	900	12.69	3.11	11.81	5.95	11.01	8.55	10.28	10.95	9.64	13.16	9.05	15.21	8.51	17.11	8.04	18.89
	1050	15.08	3.63	14.20	6.94	13.41	9.98	12.67	12.77	12.03	15.35	11.44	17.74	10.90	19.97	10.44	22.04
	1200	17.48	4.15	16.60	7.93	15.80	11.40	15.07	14.59	14.43	17.55	13.84	20.28	13.29	22.82	12.83	25.18
	1350	19.87	4.66	18.99	8.92	18.19	12.83	17.46	16.42	16.82	19.74	16.23	22.81	15.69	25.67	15.23	28.33
	1500	22.26	5.18	21.39	9.91	20.59	14.25	19.85	18.24	19.22	21.93	18.63	25.35	18.08	28.52	17.62	31.48
	1650	24.66	5.70	23.78	10.90	22.98	15.68	22.25	20.07	21.61	24.13	21.02	27.88	20.48	31.38	20.01	34.63
MRT-150	750	13.32	3.34	12.62	6.39	11.98	9.19	11.40	11.76	10.87	14.14	10.39	16.34	10.00	18.39	9.61	20.30
	900	16.40	4.01	15.70	7.67	15.06	11.03	14.49	14.11	13.95	16.97	13.48	19.61	13.09	22.07	12.70	24.36
	1050	19.49	4.68	18.79	8.95	18.15	12.86	17.58	16.47	17.04	19.80	16.57	22.88	16.18	25.75	15.78	28.41
	1200	22.58	5.35	21.88	10.23	21.24	14.70	20.66	18.82	20.13	22.62	19.65	26.15	19.26	29.42	18.87	32.47
	1350	25.66	6.02	24.96	11.50	24.33	16.54	23.75	21.17	23.21	25.45	22.74	29.42	22.35	33.10	21.96	36.53
	1500	28.75	6.68	28.05	12.78	27.41	18.38	26.84	23.52	26.30	28.28	25.83	32.69	25.44	36.78	25.05	40.59
	1650	31.84	7.35	31.14	14.06	30.50	20.21	29.92	25.88	29.39	31.11	28.91	35.96	28.52	40.46	28.13	44.65
MRT-200	600	17.01	4.84	15.95	9.27	15.04	13.32	14.21	17.06	13.53	20.51	12.93	23.71	12.40	26.68	11.98	29.45
	750	22.68	6.05	21.62	11.58	20.71	16.65	19.88	21.32	19.20	25.64	18.60	29.64	18.07	33.36	17.65	36.82
	900	28.35	7.27	27.29	13.90	26.38	19.98	25.55	25.59	24.87	30.77	24.27	35.57	23.74	40.03	23.32	44.18
	1050	34.02	8.48	32.96	16.22	32.05	23.32	31.22	29.85	30.54	35.89	29.94	41.49	29.41	46.70	28.99	51.55
	1200	39.69	9.69	38.63	18.53	37.72	26.65	36.89	34.12	36.21	41.02	35.61	47.42	35.08	53.37	34.66	58.91
	1350	45.36	10.90	44.30	20.85	43.39	29.98	42.56	38.38	41.88	46.15	41.28	53.35	40.75	60.04	40.33	66.27
	1500	51.03	12.11	49.97	23.17	49.06	33.31	48.23	42.65	47.55	51.28	46.95	59.28	46.42	66.71	46.00	73.64
MRT-200A	600	27.72	7.40	26.22	14.16	24.89	20.35	23.68	26.06	22.58	31.34	21.60	36.23	20.73	40.77	19.98	45.00
	750	36.38	9.25	34.88	17.70	33.55	25.44	32.34	32.58	31.24	39.17	30.26	45.28	29.39	50.96	28.64	56.25
	900	45.05	11.10	43.54	21.24	42.22	30.53	41.00	39.09	39.91	47.01	38.92	54.34	38.06	61.15	37.31	67.50
	1050	53.71	12.95	52.21	24.77	50.88	35.62	49.67	45.61	48.57	54.84	47.59	63.39	46.72	71.34	45.97	78.75
	1200	62.37	14.80	60.87	28.31	59.54	40.71	58.33	52.12	57.23	62.67	56.25	72.45	55.38	81.54	54.63	90.00
	1350	71.03	16.65	69.53	31.85	68.20	45.80	66.99	58.64	65.89	70.51	64.91	81.51	64.04	91.73	63.29	101.2
	1500	79.70	18.50	78.19	35.39	76.87	50.89	75.65	65.16	74.56	78.34	73.57	90.56	72.71	101.9	71.96	112.5
MRT-250	600	27.72	7.40	26.22	14.16	24.89	20.35	23.68	26.06	22.58	31.34	21.60	36.23	20.73	40.77	19.98	45.00
	750	36.38	9.25	34.88	17.70	33.55	25.44	32.34	32.58	31.24	39.17	30.26	45.28	29.39	50.96	28.64	56.25
	900	45.05	11.10	43.54	21.24	42.22	30.53	41.00	39.09	39.91	47.01	38.92	54.34	38.06	61.15	37.31	67.50
	1050	53.71	12.95	52.21	24.77	50.88	35.62	49.67	45.61	48.57	54.84	47.59	63.39	46.72	71.34	45.97	78.75
	1200	62.37	14.80	60.87	28.31	59.54	40.71	58.33	52.12	57.23	62.67	56.25	72.45	55.38	81.54	54.63	90.00
	1350	71.03	16.65	69.53	31.85	68.20	45.80	66.99	58.64	65.89	70.51	64.91	81.51	64.04	91.73	63.29	101.2
	1500	79.70	18.50	78.19	35.39	76.87	50.89	75.65	65.16	74.56	78.34	73.57	90.56	72.71	101.9	71.96	112.5

MRT-250A	600	39.45	10.36	37.54	18.02	35.93	25.92	34.56	33.71	33.33	41.48	32.19	49.20	31.19	56.8	30.35	64.3
	750	50.92	12.95	49.00	22.52	47.40	32.40	46.02	42.14	44.80	51.85	43.65	61.50	42.66	71.0	41.82	80.4
	900	62.38	15.53	60.47	27.03	58.87	38.88	57.49	50.57	56.27	62.22	55.12	73.80	54.13	85.2	53.29	96.5
	1050	73.85	18.12	71.94	31.53	70.33	45.36	68.96	58.99	67.73	72.59	66.59	86.10	65.59	99.4	64.75	112.6
	1200	85.32	20.71	83.41	36.04	81.80	51.84	80.43	67.42	79.20	82.96	78.06	98.39	77.06	113.6	76.22	128.7
	1350	96.79	23.30	94.87	40.54	93.27	58.32	91.89	75.85	90.67	93.33	89.52	110.7	88.53	127.8	87.69	144.7
	1500	108.3	25.89	106.3	45.05	104.74	64.80	103.4	84.28	102.1	103.7	101.0	123.0	100.0	142.0	99.16	160.8
MRT-300	600	58.94	14.44	55.49	25.88	53.71	37.23	52.04	47.70	50.48	58.83	49.26	68.88	47.59	79.49	46.70	88.83
	750	75.62	18.06	72.17	32.35	70.39	46.54	68.72	59.63	67.16	73.53	65.94	86.10	64.27	99.36	63.38	111.0
	900	92.30	21.67	88.85	38.82	87.07	55.85	85.40	71.55	83.84	88.24	82.62	103.3	80.95	119.2	80.06	133.3
	1050	109.0	25.28	105.5	45.29	103.7	65.16	102.1	83.48	100.5	102.9	99.30	120.5	97.63	139.1	96.74	155.5
	1200	125.7	28.89	122.2	51.76	120.4	74.46	118.8	95.41	117.2	117.7	116.0	137.8	114.3	159.0	113.4	177.7
	1350	142.3	32.50	138.9	58.23	137.1	83.77	135.4	107.3	133.9	132.4	132.7	155.0	131.0	178.8	130.1	199.9
	1500	159.0	36.11	155.6	64.70	153.8	93.08	152.1	119.3	150.6	147.1	149.3	172.2	147.7	198.7	146.8	222.1
MRT-300A	600	88.3	21.07	85.0	37.30	82.3	53.64	80.0	71.4	78.1	87.0	76.1	103.1	74.5	119.0	72.5	136.5
	700	104.7	24.58	101.4	43.52	98.7	62.58	96.4	83.3	94.5	101.5	92.5	120.3	90.9	138.9	88.9	159.3
	800	121.1	28.10	117.8	49.74	115.1	71.52	112.8	95.2	110.9	116.0	108.9	137.5	107.3	158.7	105.3	182.1
	900	137.5	31.61	134.2	55.95	131.5	80.46	129.2	107.1	127.3	130.5	125.3	154.7	123.7	178.6	121.7	204.8
	1000	153.9	35.12	150.6	62.17	147.9	89.39	145.6	119.0	143.7	145.0	141.7	171.9	140.1	198.4	138.1	227.6
	1100	170.3	38.63	167.0	68.39	164.3	98.33	162.0	130.9	160.1	159.5	158.1	189.1	156.5	218.2	154.5	250.3
	1200	186.7	42.15	183.4	74.60	180.7	107.3	178.4	142.8	176.5	174.0	174.5	206.3	172.9	238.1	170.9	273.1
MRT-350	600	138.3	32.31	133.1	58.00	129.0	83.48	125.2	109.6	121.9	134.1	119.1	160.3	116.3	182.7	113.5	212.3
	700	163.8	37.70	158.6	67.67	154.5	97.39	150.7	127.9	147.4	156.4	144.6	187.1	141.8	213.2	139.0	247.7
	800	189.3	43.08	184.1	77.33	180.0	111.3	176.2	146.2	172.9	178.8	170.1	213.8	167.3	243.7	164.5	283.1
	900	214.8	48.47	209.6	87.00	205.5	125.2	201.7	164.5	198.4	201.1	195.6	240.5	192.8	274.1	190.0	318.5
	1000	240.3	53.85	235.1	96.67	231.0	139.1	227.2	182.7	223.9	223.4	221.1	267.2	218.3	304.6	215.5	353.9
	1100	265.8	59.24	260.6	106.3	256.5	153.0	252.7	201.0	249.4	245.8	246.6	294.0	243.8	335.0	241.0	389.2
	1200	291.3	64.62	286.1	116.0	282.0	167.0	278.2	219.3	274.9	268.1	272.1	320.7	269.3	365.5	266.5	424.6
MRT-400	600	236.3	53.28	230.3	95.65	225.5	137.7	221.3	180.8	217.6	221.1	214.1	264.4	211.3	301.4	208.8	350.1
	650	257.4	57.73	251.4	103.6	246.5	149.1	242.3	195.9	238.6	239.5	235.2	286.5	232.3	326.5	229.8	379.3
	700	278.4	62.17	272.4	111.6	267.5	160.6	263.3	210.9	259.6	257.9	256.2	308.5	253.4	351.6	250.8	408.5
	750	299.4	66.61	293.4	119.6	288.6	172.1	284.4	226.0	280.7	276.4	277.2	330.5	274.4	376.7	271.9	437.7
	800	320.4	71.05	314.4	127.5	309.6	183.6	305.4	241.1	301.7	294.8	298.2	352.6	295.4	401.8	292.9	466.8
	850	341.5	75.49	335.5	135.5	330.6	195.0	326.4	256.1	322.7	313.2	319.3	374.6	316.4	426.9	313.9	496.0
	900	362.5	79.93	356.5	143.5	351.6	206.5	347.4	271.2	343.7	331.6	340.3	396.7	337.5	452.0	335.0	525.2

MRV TYPE PERFORMANCE TABLE (VACUUM Types)

TYPE	RPM	Qs(m ³ /min)								PRESSURE(mmAq)							
		-1000		-2000		-2500		-3000		-3500		-4000		-4500		-5000	
		Qs	La	Qs	La	Qs	La	Qs	La	Qs	La	Qs	La	Qs	La	Qs	La
MRV-040	1650	0.60	0.19	0.58	0.37	0.55	0.44	0.51	0.50	0.50	0.56	0.48	0.62				
	1800	0.68	0.21	0.65	0.40	0.62	0.48	0.59	0.55	0.58	0.61	0.55	0.67				
	1950	0.75	0.23	0.72	0.43	0.70	0.51	0.66	0.59	0.65	0.67	0.62	0.73				
	2100	0.83	0.24	0.80	0.47	0.77	0.55	0.74	0.64	0.72	0.72	0.70	0.79				
	2250	0.90	0.26	0.87	0.50	0.85	0.59	0.81	0.69	0.80	0.77	0.77	0.84				
	2400	0.97	0.28	0.95	0.53	0.92	0.63	0.88	0.73	0.87	0.82	0.85	0.90				
	2550	1.05	0.30	1.02	0.57	0.99	0.67	0.96	0.78	0.95	0.87	0.92	0.95				
MRV-050	850	0.99	0.41	0.82	0.80	0.72	0.98	0.61	1.16	0.51	1.34	0.36	1.51	0.27	1.67	0.14	1.84
	1000	1.31	0.48	1.14	0.94	1.04	1.16	0.93	1.37	0.83	1.57	0.69	1.77	0.59	1.97	0.46	2.16
	1150	1.63	0.56	1.47	1.08	1.36	1.33	1.25	1.57	1.15	1.81	1.01	2.04	0.91	2.27	0.79	2.49
	1300	1.95	0.63	1.79	1.22	1.69	1.50	1.58	1.78	1.48	2.05	1.33	2.31	1.24	2.56	1.11	2.81
	1450	2.27	0.70	2.11	1.36	2.01	1.68	1.90	1.98	1.80	2.28	1.65	2.57	1.56	2.86	1.43	3.13
	1600	2.60	0.77	2.43	1.50	2.33	1.85	2.22	2.19	2.12	2.52	1.97	2.84	1.88	3.15	1.75	3.46
	1750	2.92	0.85	2.75	1.64	2.65	2.02	2.54	2.39	2.44	2.75	2.29	3.11	2.20	3.45	2.07	3.78
MRV-065	850	2.09	0.66	1.91	1.28	1.80	1.58	1.68	1.87	1.55	2.15	1.41	2.42	1.26	2.69	1.09	2.95
	1000	2.60	0.78	2.43	1.51	2.32	1.86	2.19	2.20	2.07	2.53	1.92	2.85	1.77	3.16	1.60	3.47
	1150	3.12	0.89	2.95	1.73	2.84	2.14	2.71	2.53	2.58	2.91	2.44	3.28	2.29	3.64	2.12	3.99
	1300	3.64	1.01	3.46	1.96	3.35	2.41	3.23	2.86	3.10	3.29	2.96	3.71	2.81	4.11	2.64	4.51
	1450	4.15	1.13	3.98	2.19	3.87	2.69	3.74	3.19	3.62	3.67	3.47	4.13	3.32	4.59	3.15	5.03
	1600	4.67	1.24	4.50	2.41	4.39	2.97	4.26	3.52	4.13	4.05	3.99	4.56	3.84	5.06	3.67	5.55
	1750	5.19	1.36	5.01	2.64	4.90	3.25	4.78	3.85	4.65	4.42	4.51	4.99	4.36	5.54	4.19	6.08
MRV-080	850	3.24	1.12	2.83	2.14	2.60	2.62	2.36	3.08	2.10	3.52	1.83	3.94	1.54	4.34	1.23	4.73
	1000	4.14	1.32	3.73	2.52	3.50	3.08	3.26	3.62	3.00	4.14	2.73	4.63	2.44	5.11	2.13	5.57
	1150	5.04	1.51	4.63	2.90	4.40	3.54	4.16	4.16	3.90	4.76	3.63	5.33	3.34	5.88	3.03	6.40
	1300	5.94	1.71	5.53	3.27	5.30	4.01	5.06	4.71	4.80	5.38	4.53	6.02	4.24	6.64	3.93	7.24
	1450	6.84	1.91	6.43	3.65	6.20	4.47	5.96	5.25	5.70	6.00	5.43	6.72	5.14	7.41	4.83	8.08
	1600	7.74	2.11	7.33	4.03	7.10	4.93	6.86	5.79	6.60	6.62	6.33	7.41	6.04	8.18	5.73	8.91
	1750	8.64	2.30	8.23	4.41	8.00	5.39	7.76	6.33	7.50	7.24	7.23	8.11	6.94	8.94	6.63	9.75
MRV-100	850	5.79	1.57	5.19	3.00	4.85	3.67	4.48	4.31	4.09	4.92	3.67	5.51	3.22	6.08	2.74	6.63
	1000	7.05	1.84	6.45	3.53	6.11	4.31	5.74	5.07	5.35	5.79	4.93	6.49	4.48	7.15	4.00	7.80
	1150	8.31	2.12	7.71	4.05	7.37	4.96	7.00	5.83	6.61	6.66	6.19	7.46	5.74	8.23	5.26	8.97
	1300	9.57	2.40	8.97	4.58	8.63	5.61	8.26	6.59	7.87	7.53	7.45	8.43	7.00	9.30	6.52	10.14
	1450	10.83	2.67	10.23	5.11	9.89	6.25	9.52	7.35	9.13	8.40	8.71	9.41	8.26	10.37	7.78	11.31
	1600	12.09	2.95	11.49	5.64	11.15	6.90	10.78	8.11	10.39	9.27	9.97	10.38	9.52	11.45	9.04	12.47
	1750	13.35	3.23	12.75	6.17	12.41	7.55	12.04	8.87	11.65	10.14	11.23	11.35	10.78	12.52	10.30	13.64



MRV-125S	750	8.13	2.05	7.35	3.91	6.93	4.79	6.48	5.63	6.01	6.43	5.53	7.20	5.00	7.94	4.46	8.66
	900	10.02	2.46	9.24	4.70	8.82	5.75	8.37	6.75	7.90	7.72	7.42	8.64	6.89	9.53	6.35	10.39
	1050	11.91	2.86	11.13	5.48	10.71	6.70	10.26	7.88	9.79	9.00	9.31	10.08	8.78	11.12	8.24	12.12
	1200	13.80	3.27	13.02	6.26	12.60	7.66	12.15	9.00	11.68	10.29	11.20	11.52	10.67	12.71	10.13	13.85
	1350	15.69	3.68	14.91	7.04	14.49	8.62	14.04	10.13	13.57	11.57	13.09	12.96	12.56	14.30	12.02	15.59
	1500	17.58	4.09	16.80	7.83	16.38	9.58	15.93	11.25	15.46	12.86	14.98	14.40	14.45	15.89	13.91	17.32
	1650	19.47	4.50	18.69	8.61	18.27	10.53	17.82	12.38	17.35	14.14	16.87	15.84	16.34	17.48	15.80	19.05
MRV-125	750	10.29	2.59	9.30	4.96	8.78	6.06	8.20	7.13	7.61	8.14	7.01	9.12	6.34	10.06	5.65	10.97
	900	12.69	3.11	11.70	5.95	11.17	7.28	10.60	8.55	10.01	9.77	9.40	10.95	8.73	12.07	8.04	13.16
	1050	15.08	3.63	14.09	6.94	13.57	8.49	12.99	9.98	12.40	11.40	11.79	12.77	11.12	14.09	10.44	15.35
	1200	17.48	4.15	16.49	7.93	15.96	9.70	15.39	11.40	14.79	13.03	14.19	14.59	13.52	16.10	12.83	17.55
	1350	19.87	4.66	18.88	8.92	18.35	10.92	17.78	12.83	17.19	14.66	16.58	16.42	15.91	18.11	15.23	19.74
	1500	22.26	5.18	21.27	9.91	20.75	12.13	20.17	14.25	19.58	16.29	18.98	18.24	18.31	20.12	17.62	21.93
	1650	24.66	5.70	23.67	10.90	23.14	13.34	22.57	15.68	21.98	17.92	21.37	20.07	20.70	22.14	20.01	24.13
MRV-150	750	13.32	3.34	12.55	6.39	12.14	7.82	11.69	9.19	11.20	10.50	10.68	11.76	10.13	12.97	9.55	14.14
	900	16.40	4.01	15.64	7.67	15.23	9.38	14.78	11.03	14.28	12.60	13.77	14.11	13.21	15.57	12.64	16.97
	1050	19.49	4.68	18.73	8.95	18.32	10.95	17.86	12.86	17.37	14.70	16.86	16.47	16.30	18.16	15.72	19.80
	1200	22.58	5.35	21.81	10.23	21.40	12.51	20.95	14.70	20.46	16.80	19.94	18.82	19.39	20.76	18.81	22.62
	1350	25.66	6.02	24.90	11.50	24.49	14.07	24.04	16.54	23.54	18.90	23.03	21.17	22.47	23.35	21.90	25.45
	1500	28.75	6.68	27.99	12.78	27.58	15.64	27.12	18.38	26.63	21.00	26.12	23.52	25.56	25.95	24.98	28.28
	1650	31.84	7.35	31.08	14.06	30.66	17.20	30.21	20.21	29.72	23.10	29.20	25.88	28.65	28.54	28.07	31.11
MRV-200	600	17.01	4.84	15.99	9.27	15.42	11.34	14.86	13.32	14.21	15.23	13.49	17.06	12.78	18.82	11.98	20.51
	750	22.68	6.05	21.66	11.58	21.09	14.17	20.53	16.65	19.88	19.04	19.16	21.32	18.45	23.52	17.65	25.64
	900	28.35	7.27	27.33	13.90	26.76	17.01	26.20	19.98	25.55	22.84	24.83	25.59	24.12	28.23	23.32	30.77
	1050	34.02	8.48	33.00	16.22	32.43	19.84	31.87	23.32	31.22	26.65	30.50	29.85	29.79	32.93	28.99	35.89
	1200	39.69	9.69	38.67	18.53	38.10	22.67	37.54	26.65	36.89	30.46	36.17	34.12	35.46	37.64	34.66	41.02
	1350	45.36	10.90	44.34	20.85	43.77	25.51	43.21	29.98	42.56	34.26	41.84	38.38	41.13	42.34	40.33	46.15
	1500	51.03	12.11	50.01	23.17	49.44	28.34	48.88	33.31	48.23	38.07	47.51	42.65	46.80	47.05	46.00	51.28
MRV-200A	600	27.72	7.40	26.22	14.16	25.35	17.32	24.43	20.35	23.45	23.27	22.35	26.06	21.19	28.75	19.98	31.34
	750	36.38	9.25	34.88	17.70	34.01	21.65	33.09	25.44	32.11	29.08	31.01	32.58	29.86	35.94	28.64	39.17
	900	45.05	11.10	43.54	21.24	42.68	25.98	41.75	30.53	40.77	34.90	39.67	39.09	38.52	43.13	37.31	47.01
	1050	53.71	12.95	52.21	24.77	51.34	30.31	50.42	35.62	49.43	40.72	48.34	45.61	47.18	50.31	45.97	54.84
	1200	62.37	14.80	60.87	28.31	60.00	34.64	59.08	40.71	58.10	46.53	57.00	52.12	55.84	57.50	54.63	62.67
	1350	71.03	16.65	69.53	31.85	68.66	38.97	67.74	45.80	66.76	52.35	65.66	58.64	64.51	64.69	63.29	70.51
	1500	79.7	18.50	78.2	35.39	77.3	43.30	76.4	50.89	75.4	58.16	74.3	65.16	73.17	71.88	71.96	78.34
MRV-250	600	27.72	7.40	26.22	14.16	25.35	17.32	24.43	20.35	23.45	23.27	22.35	26.06	21.19	28.75	19.98	31.34
	750	36.38	9.25	34.88	17.70	34.01	21.65	33.09	25.44	32.11	29.08	31.01	32.58	29.86	35.94	28.64	39.17
	900	45.05	11.10	43.54	21.24	42.68	25.98	41.75	30.53	40.77	34.90	39.67	39.09	38.52	43.13	37.31	47.01
	1050	53.71	12.95	52.21	24.77	51.34	30.31	50.42	35.62	49.43	40.72	48.34	45.61	47.18	50.31	45.97	54.84
	1200	62.37	14.80	60.87	28.31	60.00	34.64	59.08	40.71	58.10	46.53	57.00	52.12	55.84	57.50	54.63	62.67
	1350	71.03	16.65	69.53	31.85	68.66	38.97	67.74	45.80	66.76	52.35	65.66	58.64	64.51	64.69	63.29	70.51
	1500	79.70	18.50	78.19	35.39	77.33	43.30	76.40	50.89	75.42	58.16	74.32	65.16	73.17	71.88	71.96	78.34
	600	39.31	10.34	37.13	17.81	35.63	21.47	34.37	25.13	33.01	28.89	31.74	32.48	30.37	35.83	28.82	39.97



MRV-250A	750	50.78	12.92	48.60	22.26	47.09	26.84	45.84	31.41	44.48	36.12	43.21	40.59	41.83	44.78	40.29	49.97
	900	62.25	15.50	60.07	26.72	58.56	32.21	57.31	37.70	55.95	43.34	54.68	48.71	53.30	53.74	51.76	59.96
	1050	73.71	18.09	71.53	31.17	70.03	37.57	68.77	43.98	67.41	50.57	66.14	56.83	64.77	62.70	63.22	69.95
	1200	85.18	20.67	83.00	35.62	81.50	42.94	80.24	50.26	78.88	57.79	77.61	64.95	76.24	71.65	74.69	79.95
	1350	96.65	23.26	94.47	40.07	92.96	48.31	91.71	56.55	90.35	65.01	89.08	73.07	87.70	80.61	86.16	89.94
	1500	108.1	25.84	105.9	44.53	104.4	53.68	103.2	62.83	101.8	72.24	100.5	81.19	99.17	89.57	97.63	99.93
MRV-300	600	58.94	14.25	56.27	27.26	54.82	33.35	53.15	39.19	51.49	44.80	49.71	50.18	47.70	55.36	45.70	60.34
	750	75.62	17.81	72.95	34.07	71.50	41.69	69.83	48.99	68.17	56.00	66.39	62.72	64.38	69.20	62.38	75.42
	900	92.30	21.38	89.63	40.89	88.18	50.02	86.51	58.79	84.85	67.20	83.07	75.27	81.06	83.04	79.06	90.51
	1050	109.0	24.94	106.3	47.70	104.9	58.36	103.2	68.58	101.5	78.40	99.75	87.81	97.74	96.88	95.74	105.6
	1200	125.7	28.50	123.0	54.52	121.5	66.70	119.9	78.38	118.2	89.60	116.4	100.4	114.4	110.7	112.4	120.7
	1350	142.3	32.06	139.7	61.33	138.2	75.04	136.6	88.18	134.9	100.8	133.1	112.9	131.1	124.6	129.1	135.8
	1500	159.0	35.63	156.3	68.15	154.9	83.37	153.2	97.98	151.6	112.0	149.8	125.4	147.8	138.4	145.8	150.8
MRV-300A	600	88.2	21.04	84.4	36.86	82.0	44.47	79.7	53.34	77.7	60.6	75.3	68.0	72.5	77.0	69.0	84.7
	700	104.6	24.54	100.9	43.01	98.4	51.88	96.2	62.23	94.1	70.6	91.8	79.4	89.0	89.8	85.5	98.9
	800	121.0	28.05	117.3	49.15	114.8	59.29	112.6	71.12	110.5	80.7	108.2	90.7	105.4	102.7	101.9	113.0
	900	137.5	31.56	133.7	55.29	131.3	66.70	129.1	80.00	127.0	90.8	124.7	102.0	121.8	115.5	118.4	127.1
	1000	153.9	35.06	150.2	61.44	147.7	74.11	145.5	88.89	143.4	100.9	141.1	113.4	138.3	128.3	134.8	141.2
	1100	170.3	38.57	166.6	67.58	164.1	81.52	161.9	97.78	159.9	111.0	157.5	124.7	154.7	141.2	151.2	155.3
	1200	186.8	42.07	183.0	73.72	180.6	88.93	178.4	106.7	176.3	121.1	174.0	136.1	171.1	154.0	167.7	169.5
MRV-350	600	138.1	32.72	132.3	57.32	128.5	69.15	124.7	82.94	121.4	94.16	117.9	105.8	113.5	119.8	107.9	131.7
	700	163.6	38.17	157.8	66.87	154.0	80.67	150.2	96.77	146.9	109.9	143.4	123.4	139.0	139.7	133.4	153.7
	800	189.1	43.63	183.3	76.42	179.5	92.20	175.7	110.6	172.4	125.6	168.9	141.1	164.5	159.7	158.9	175.7
	900	214.6	49.08	208.8	85.97	205.0	103.7	201.2	124.4	197.9	141.2	194.4	158.7	190.0	179.6	184.4	197.6
	1000	240.1	54.53	234.3	95.53	230.5	115.2	226.7	138.2	223.4	156.9	219.9	176.3	215.5	199.6	209.9	219.6
	1100	265.6	59.99	259.8	105.1	256.0	126.8	252.2	152.1	248.9	172.6	245.4	193.9	241.0	219.6	235.4	241.5
	1200	291.1	65.44	285.3	114.6	281.5	138.3	277.7	165.9	274.4	188.3	270.9	211.6	266.5	239.5	260.9	263.5
MRV-400	600	236.3	52.99	228.3	95.77	224.6	117.3	219.5	137.9	216.6	159.0	212.4	180.5	209.4	212.8	203.5	223.0
	650	257.4	57.40	249.4	103.8	245.6	127.1	240.5	149.4	237.6	172.3	233.4	195.5	230.5	230.5	224.6	241.6
	700	278.4	61.82	270.4	111.7	266.6	136.8	261.6	160.9	258.6	185.5	254.4	210.6	251.5	248.3	245.6	260.2
	750	299.4	66.23	291.4	119.7	287.6	146.6	282.6	172.4	279.7	198.8	275.4	225.6	272.5	266.0	266.6	278.8
	800	320.4	70.65	312.5	127.7	308.7	156.4	303.6	183.9	300.7	212.0	296.5	240.7	293.5	283.7	287.6	297.3
	850	341.5	75.07	333.5	135.7	329.7	166.2	324.6	195.4	321.7	225.3	317.5	255.7	314.6	301.5	308.7	315.9
	900	362.5	79.48	354.5	143.7	350.7	175.9	345.7	206.9	342.7	238.5	338.5	270.7	335.6	319.2	329.7	334.5

MRT PRESSURE PERFORMANCE CURVE

MRT-040

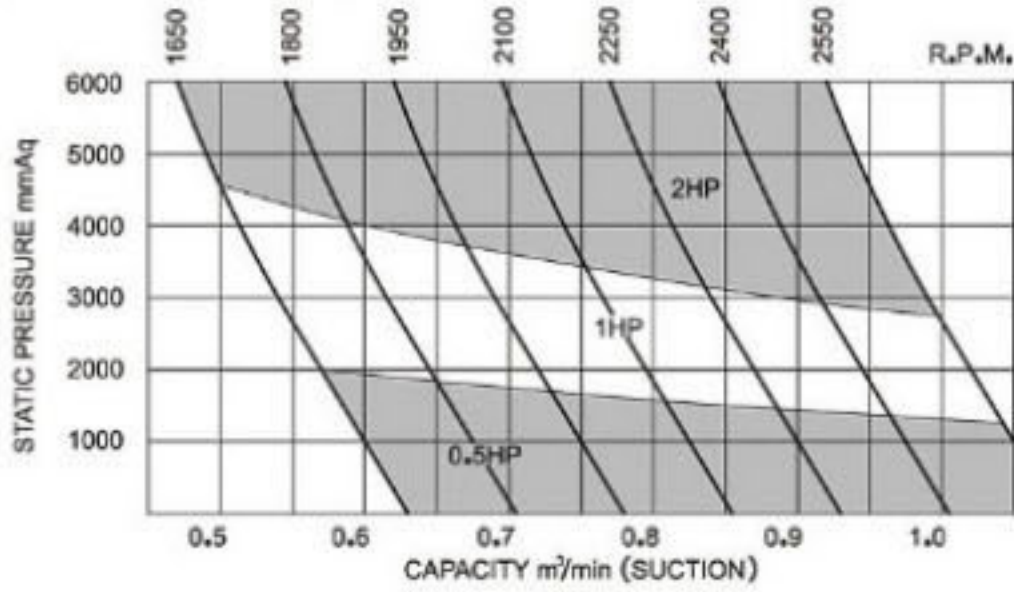

MRT-100

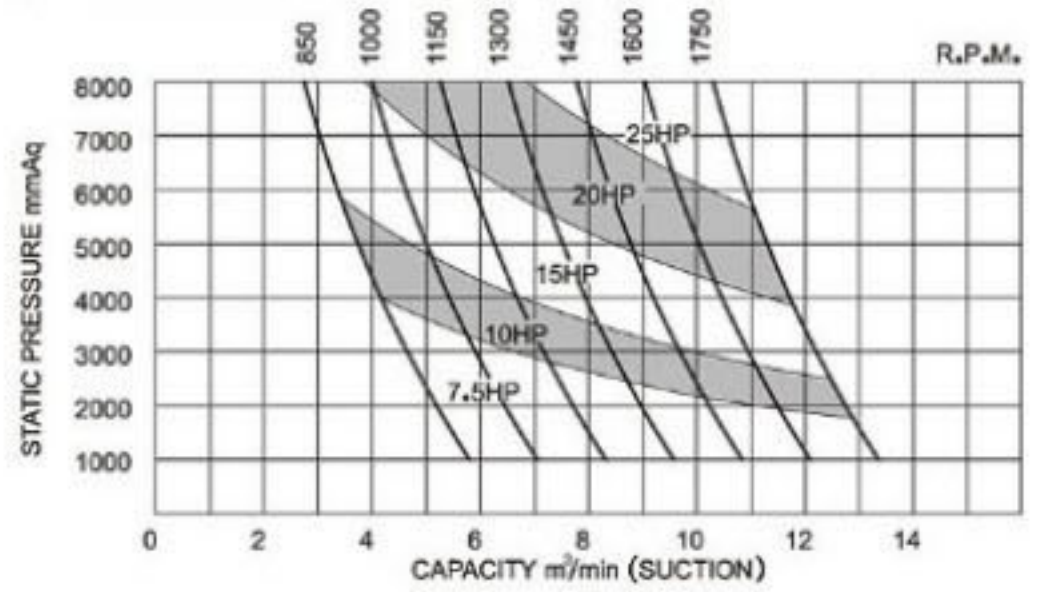

MRT-050

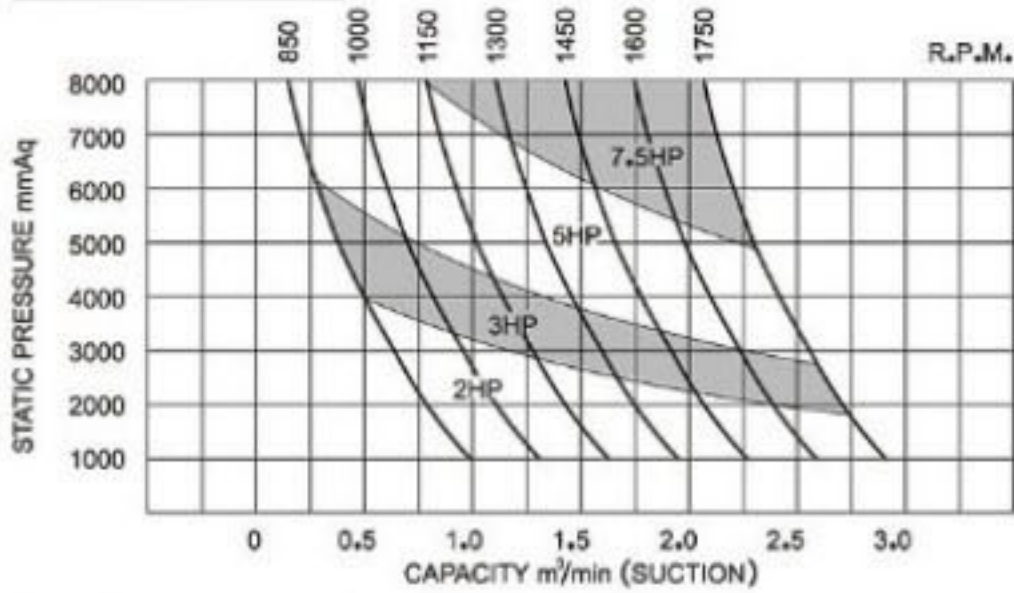

MRT-125S

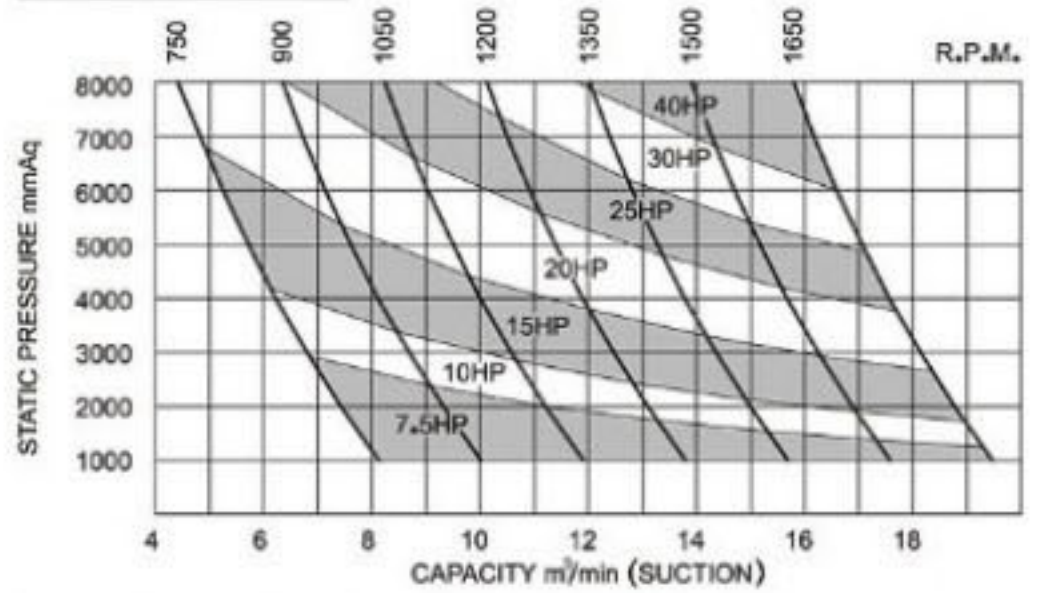

MRT-065

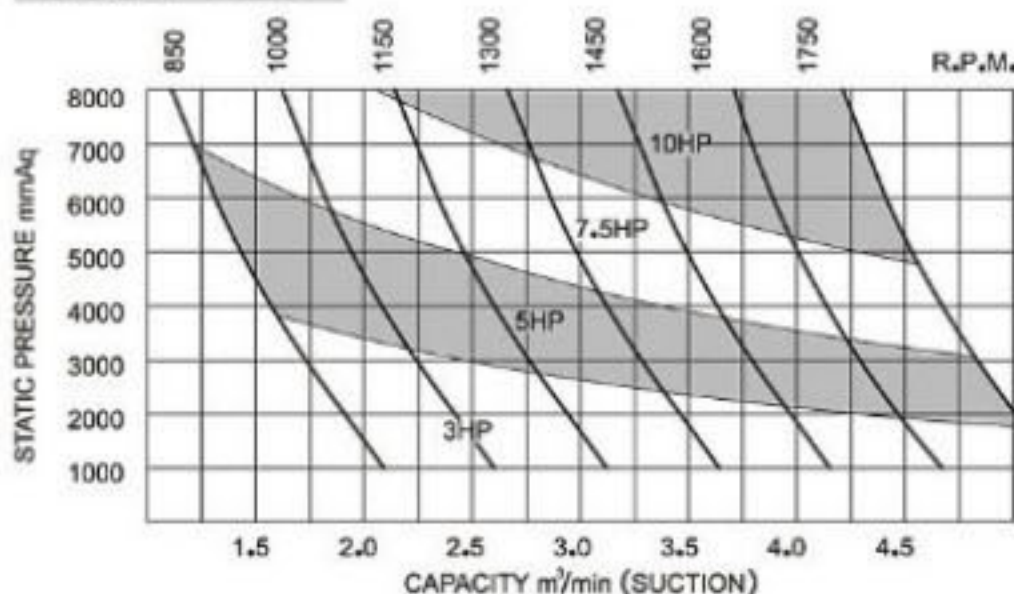

MRT-125

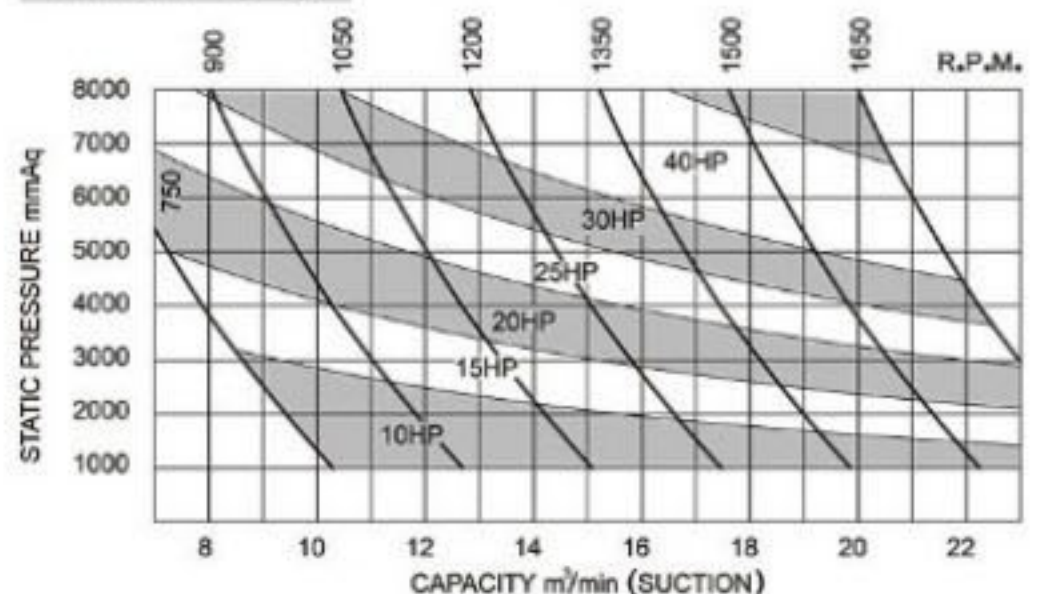

MRT-080

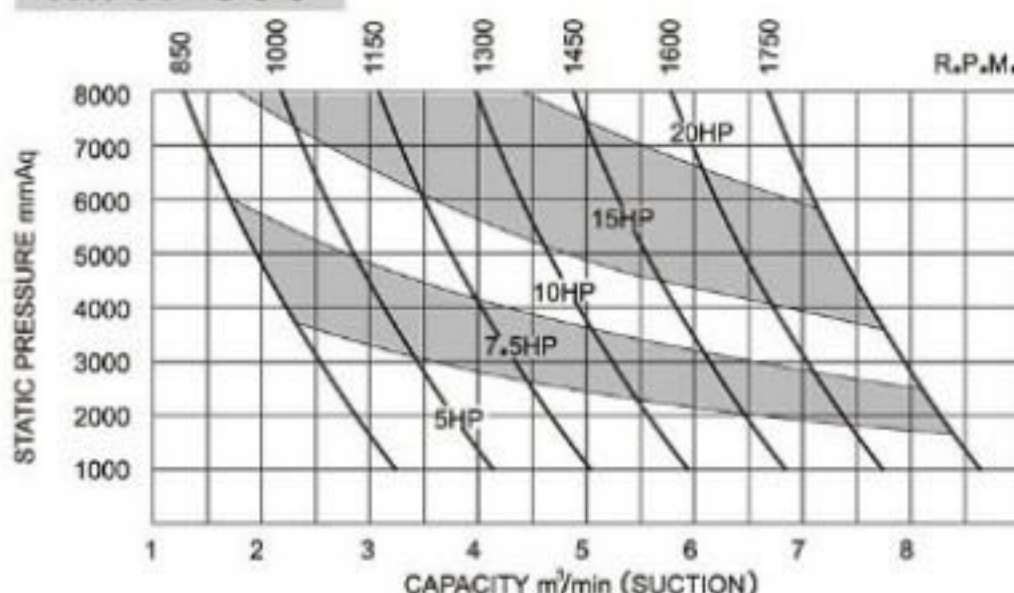

MRT-150

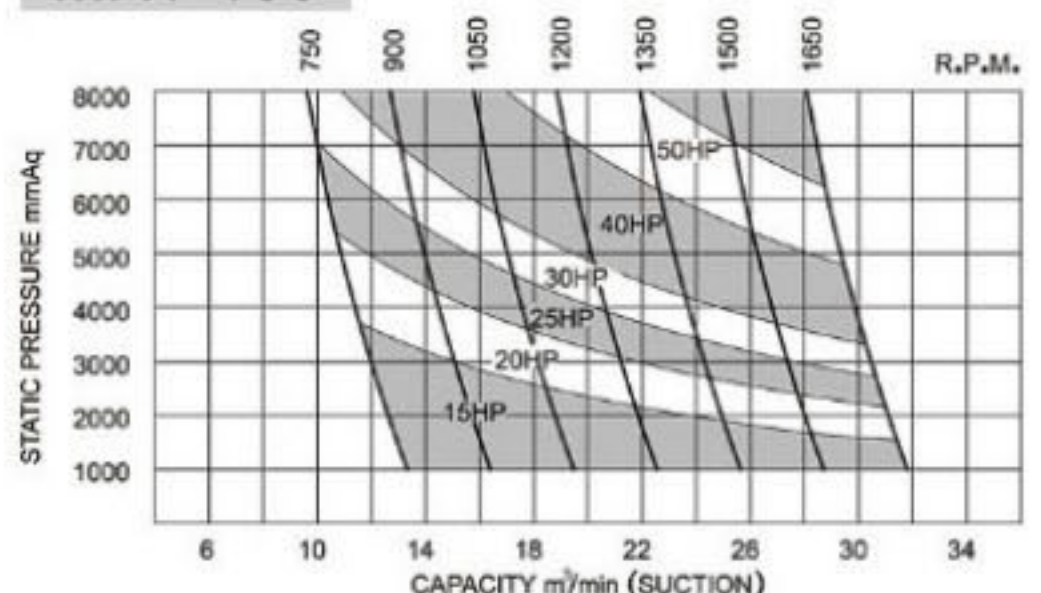

MRT PRESSURE PERFORMANCE CURVE

MRT-200

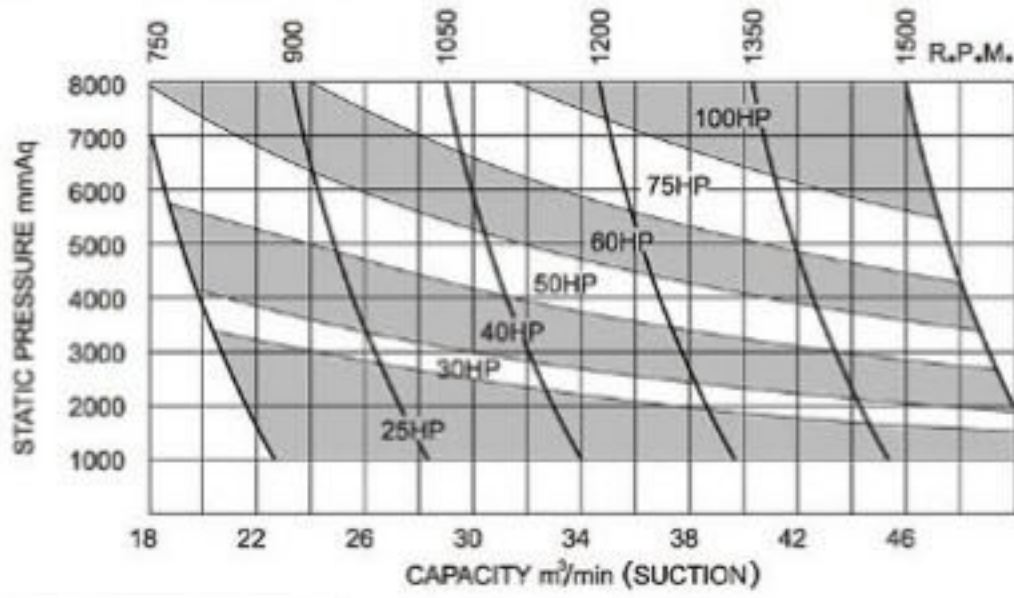

MRT-300

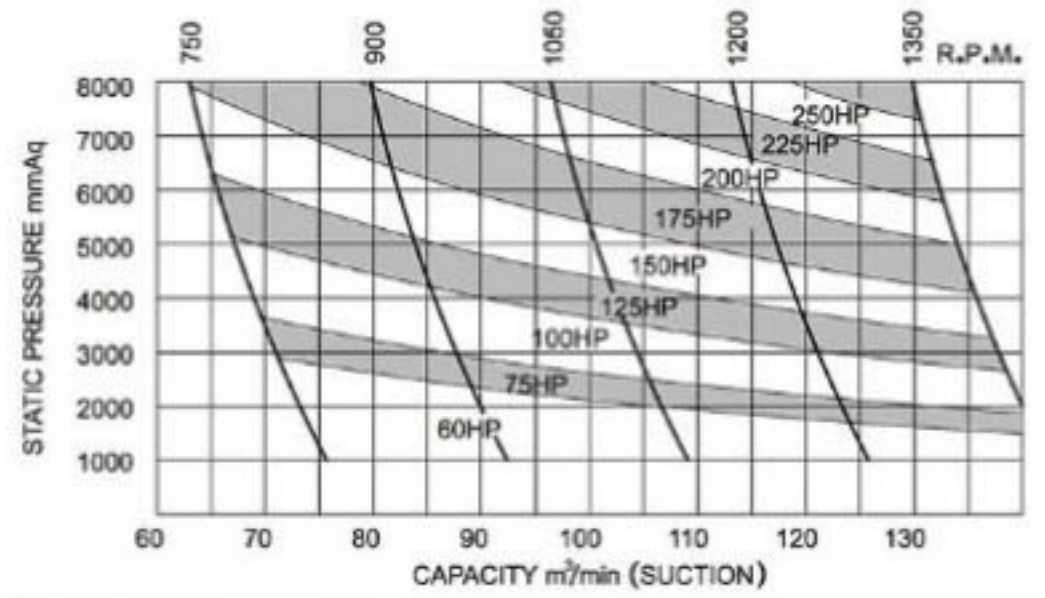

MRT-200A

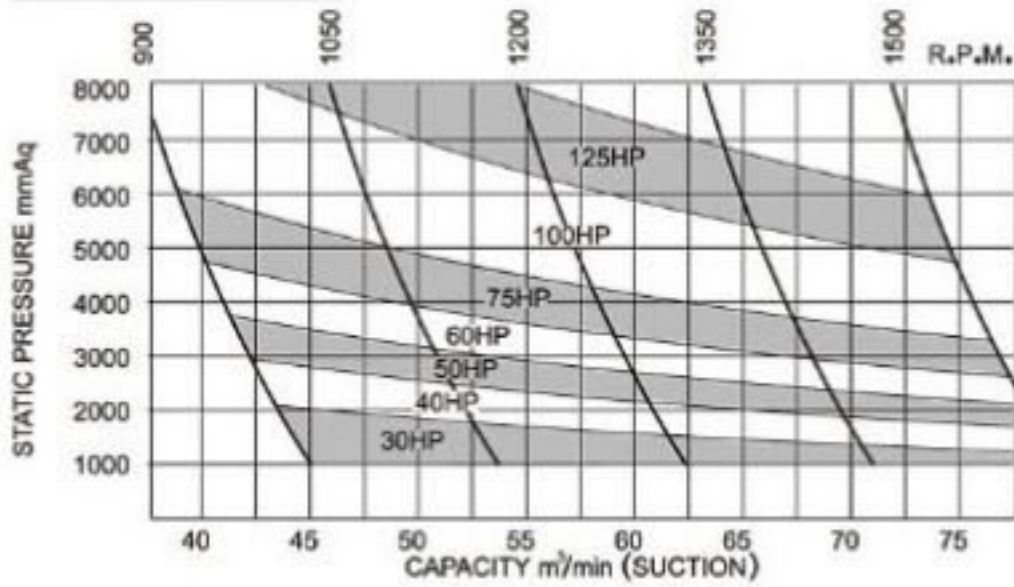

MRT-300A

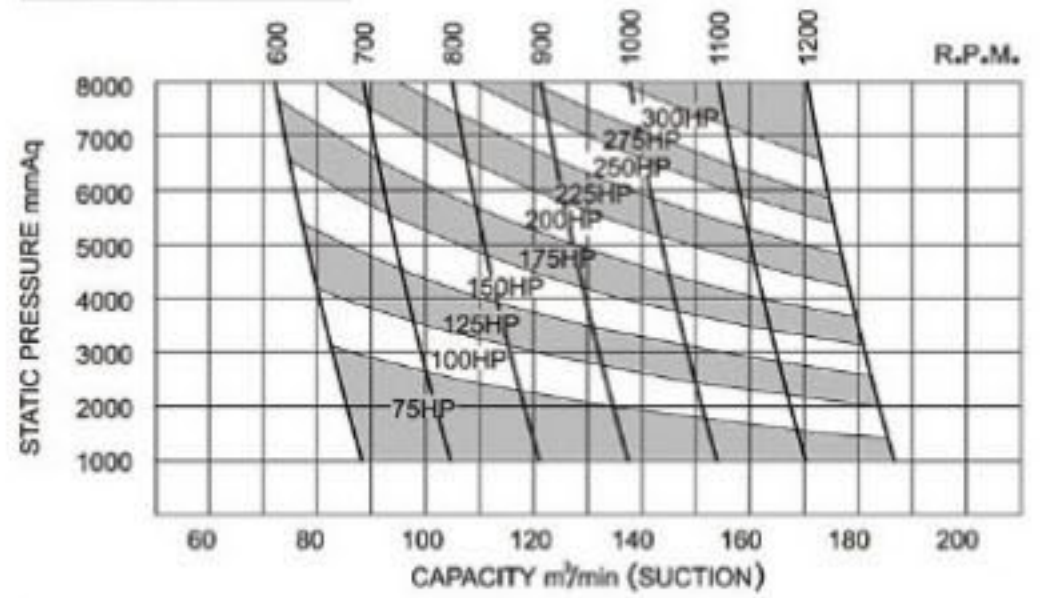

MRT-250

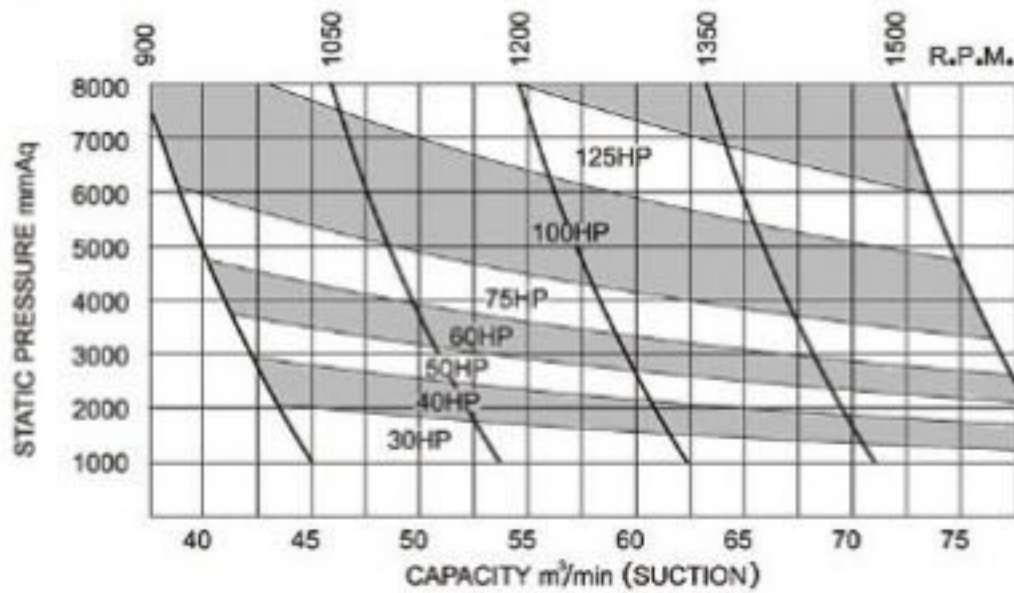

MRT-350

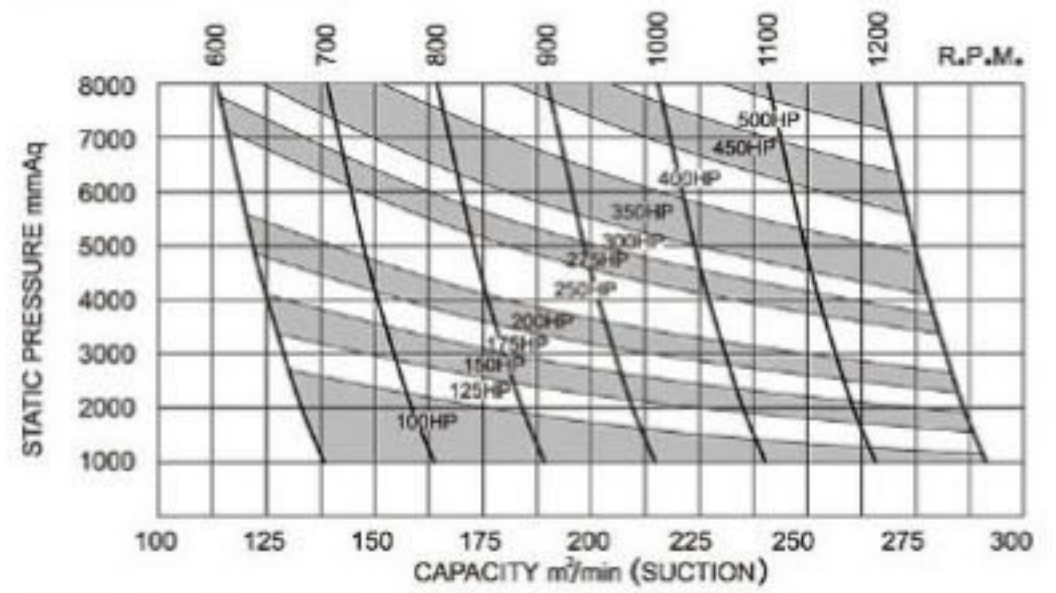

MRT-250A

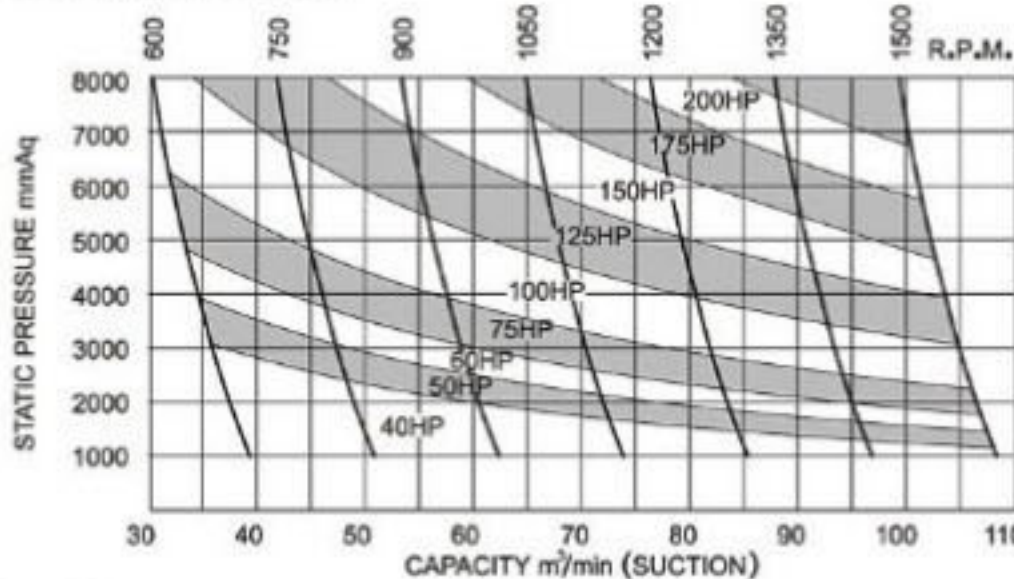

MRT-400

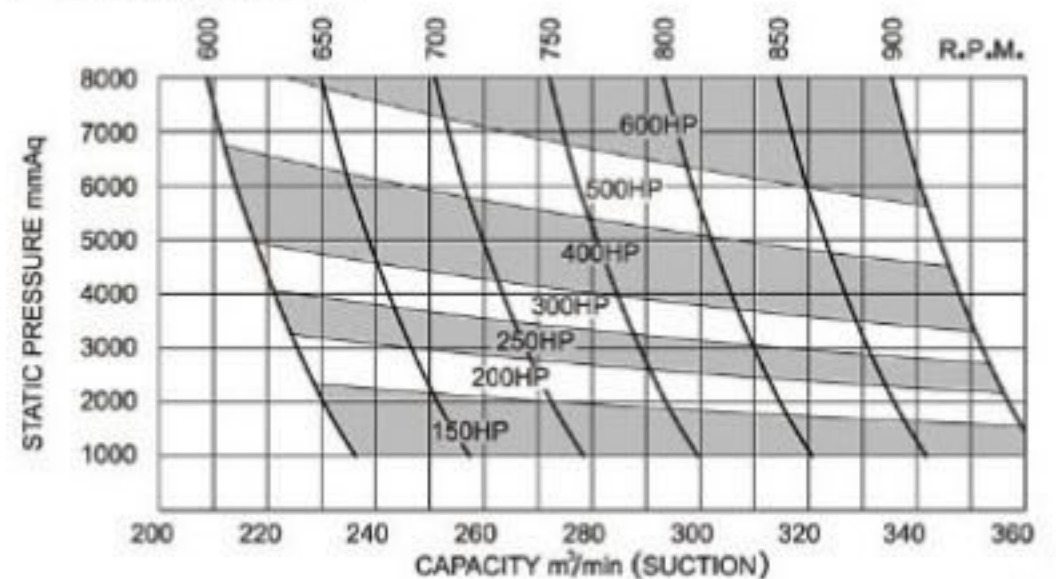

MRV VACUUM PERFORMANCE CURVE

MRV-040

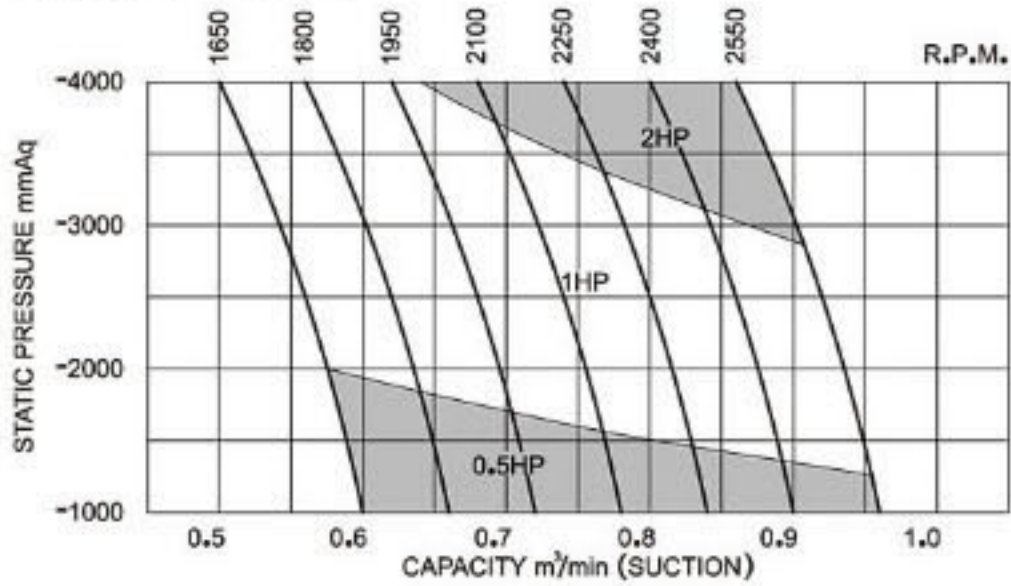

MRV-100

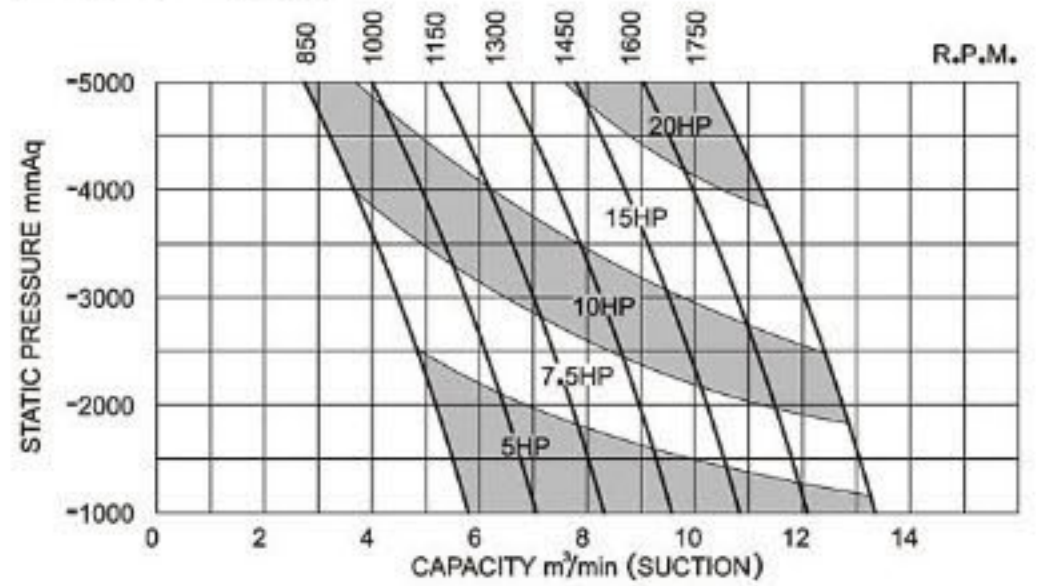

MRV-050

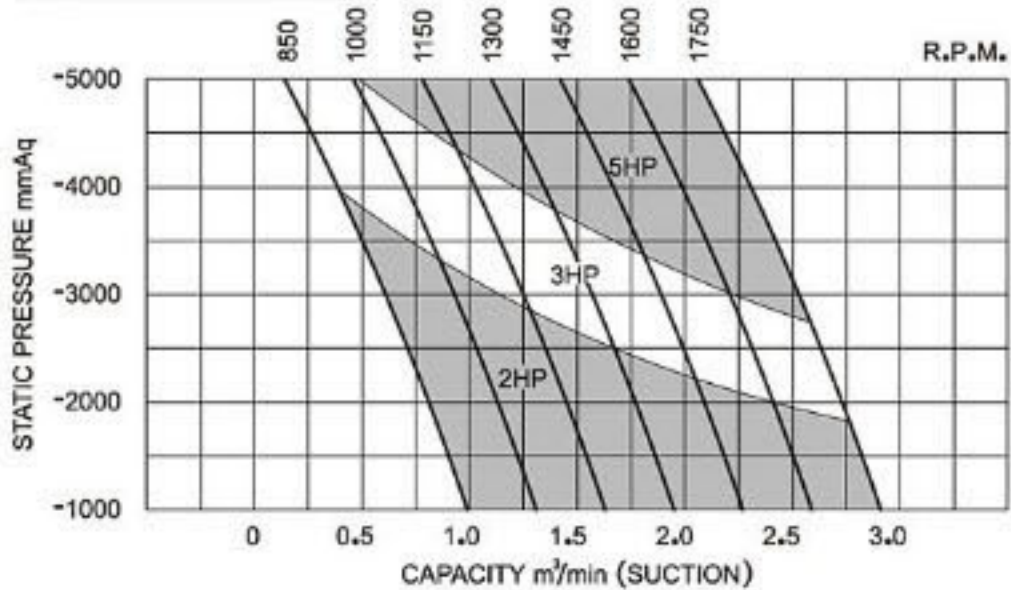

MRV-125S

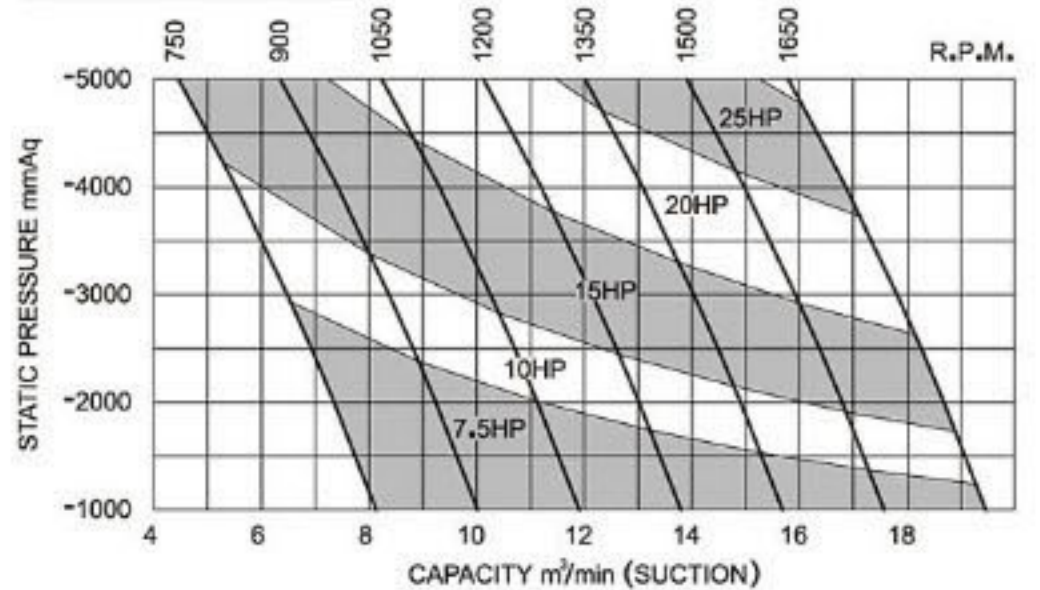

MRV-065

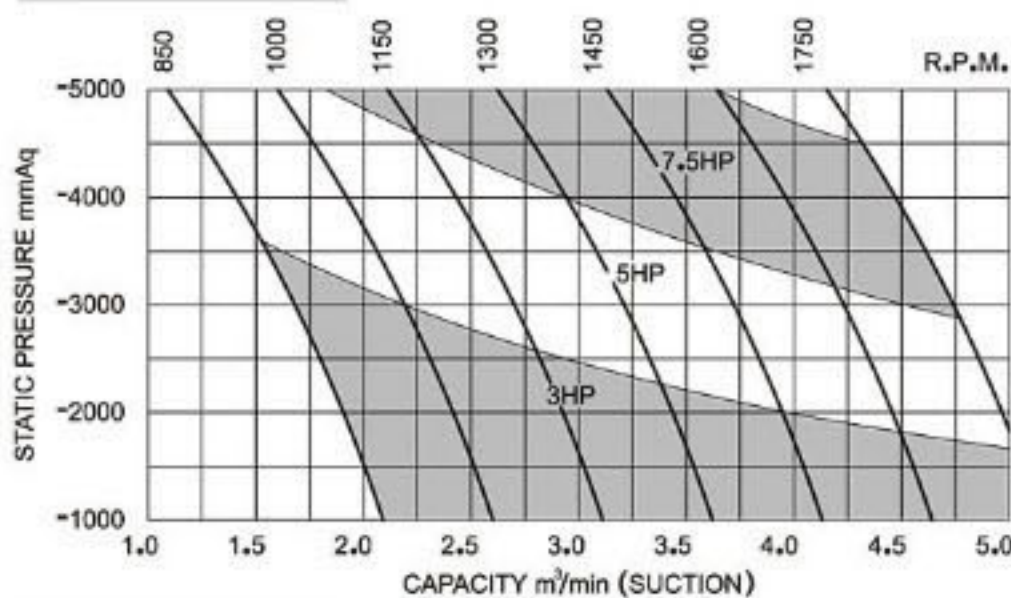

MRV-125

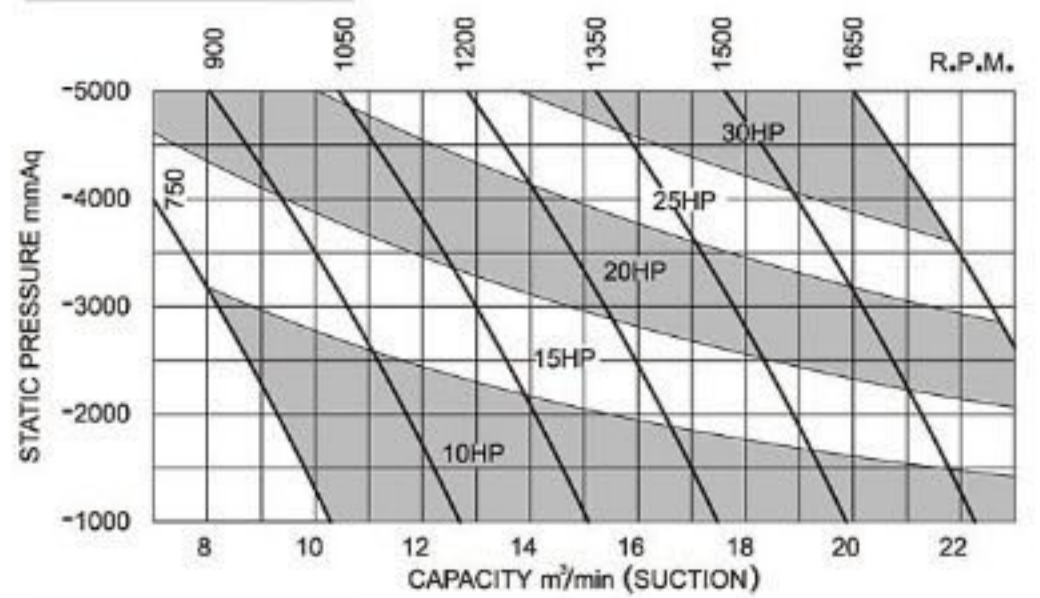

MRV-080

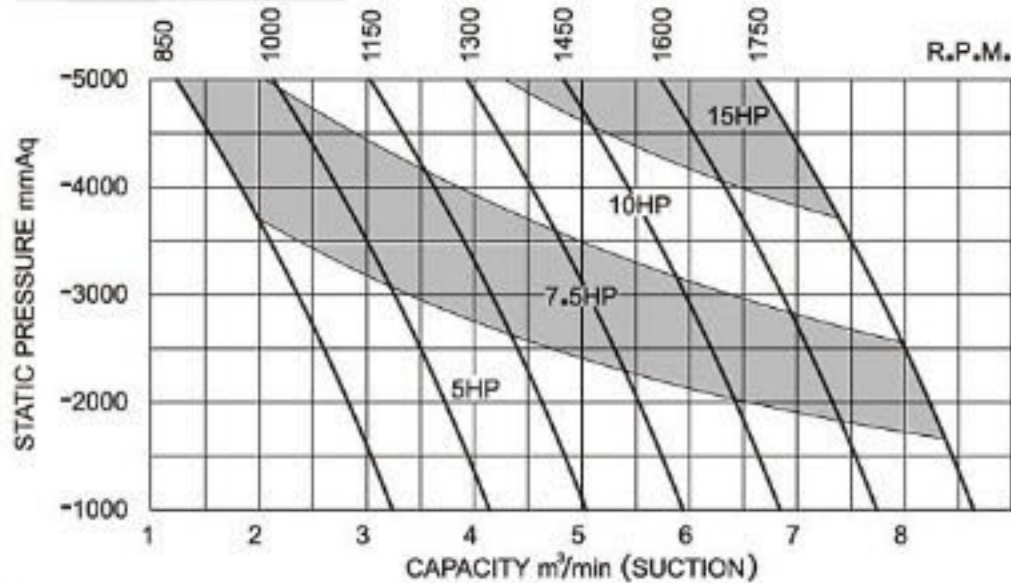

MRV-150

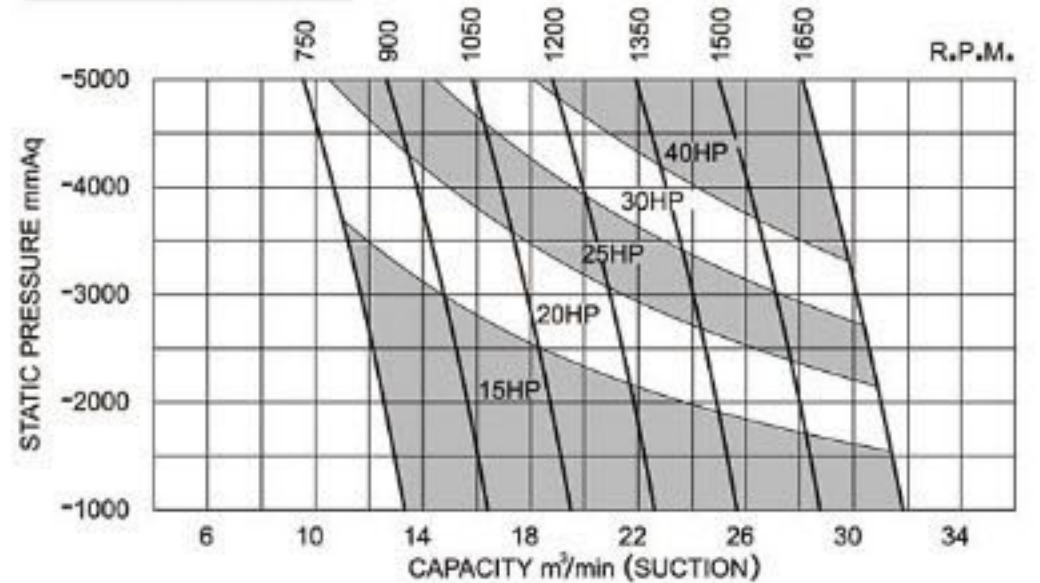

MRV VACUUM PERFORMANCE CURVE

MRV-200

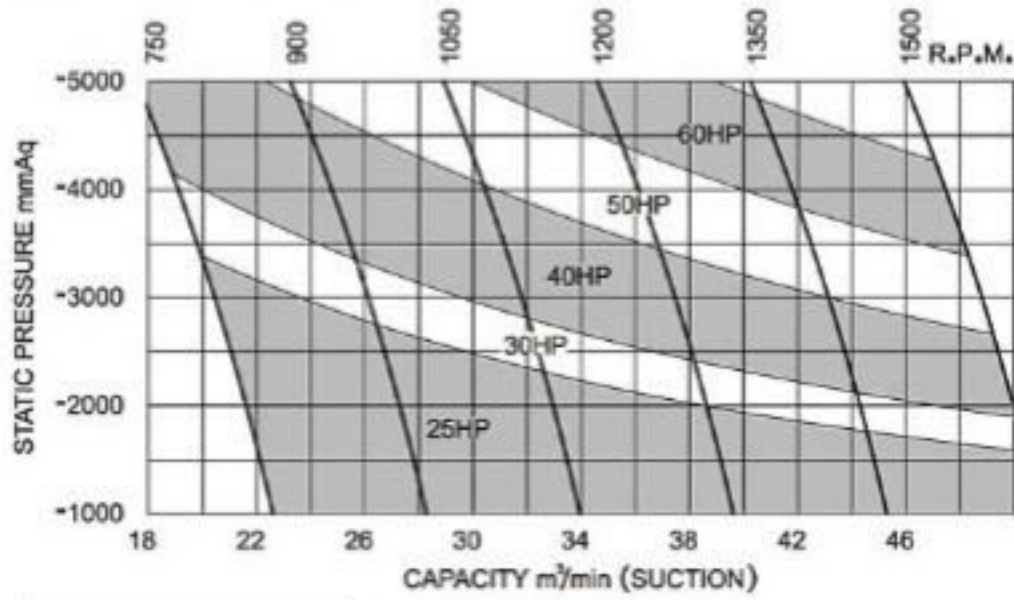

MRV-300

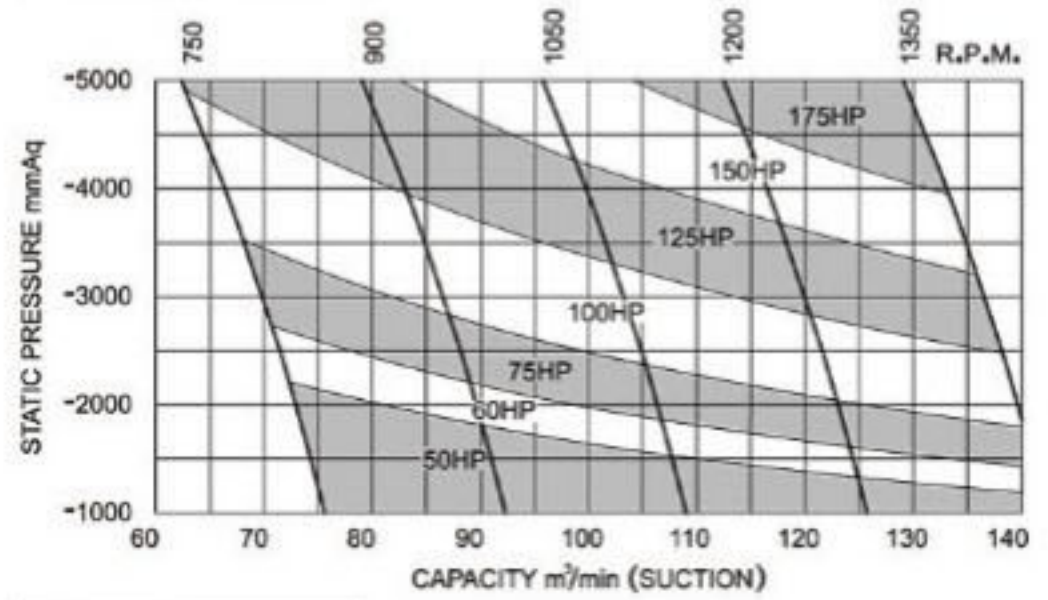

MRV-200A

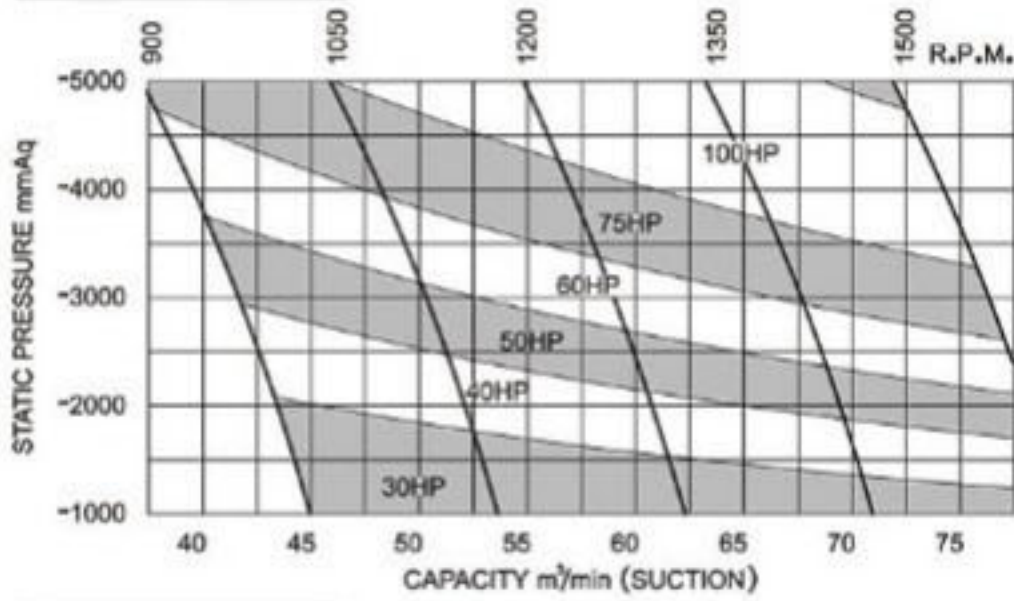

MRV-300A

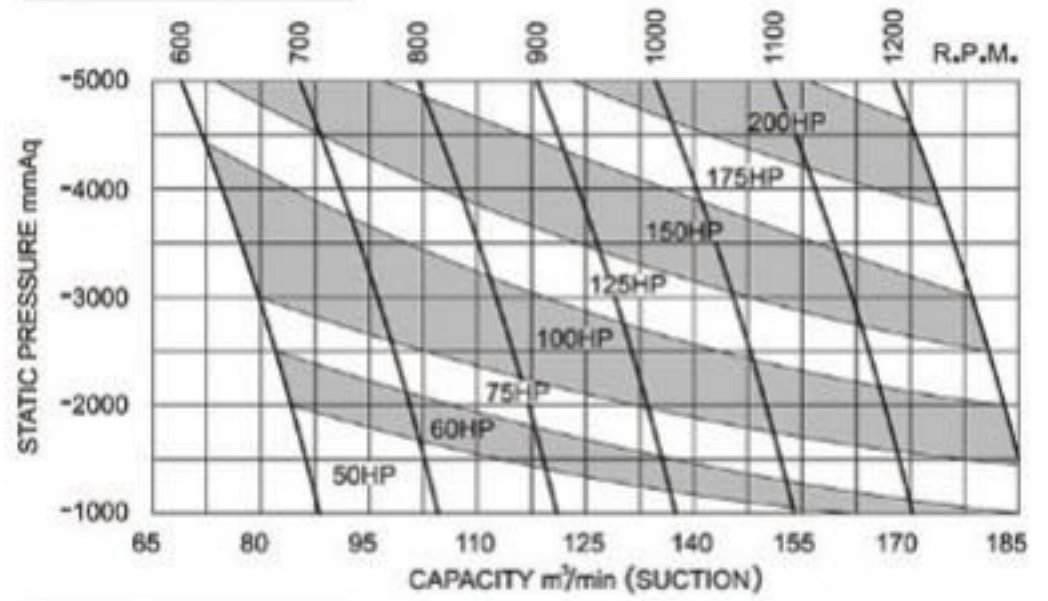

MRV-250

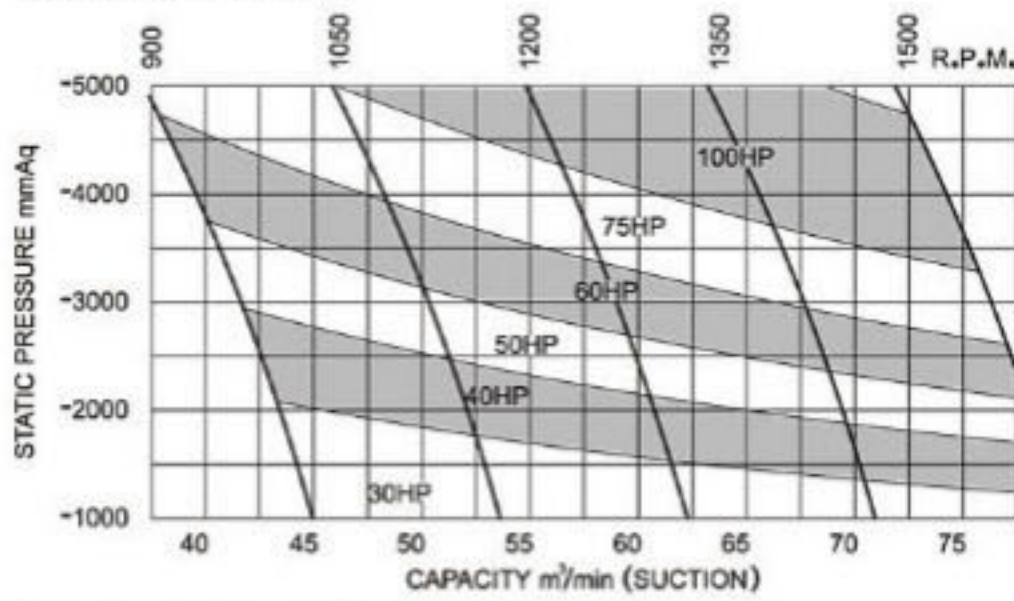

MRV-350

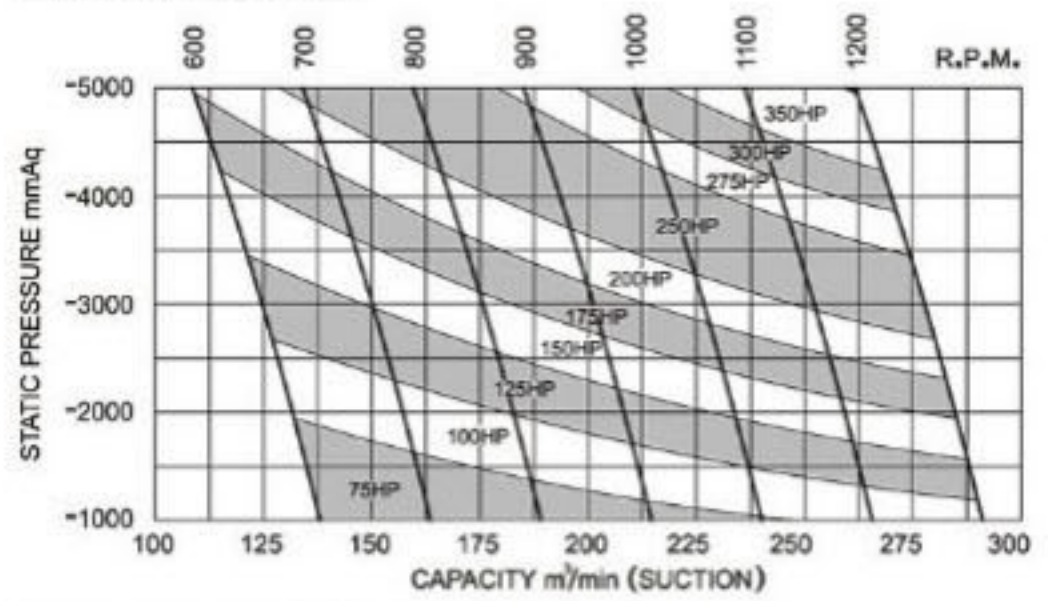

MRV-250A

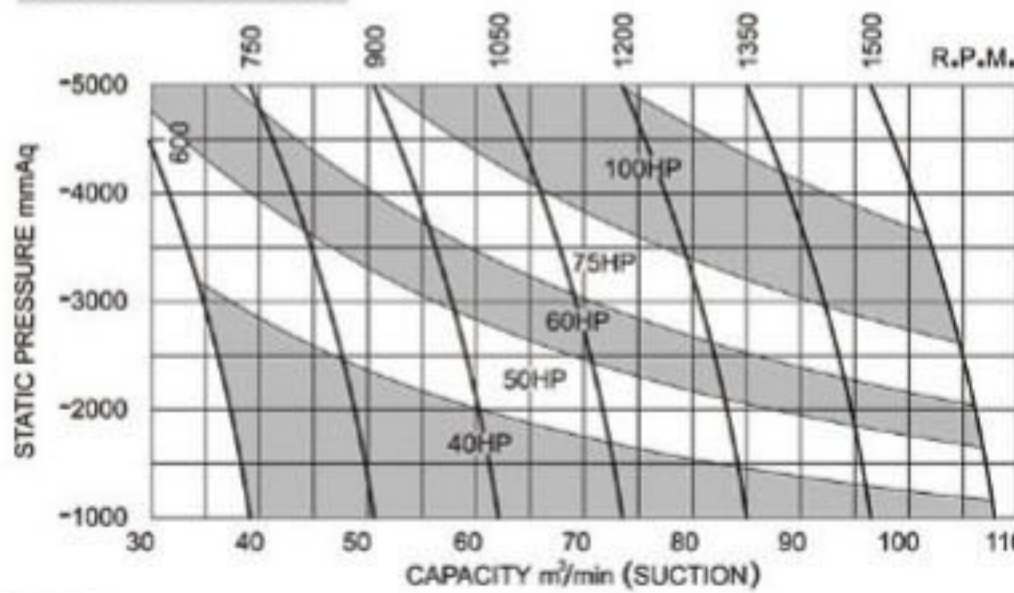

MRV-400

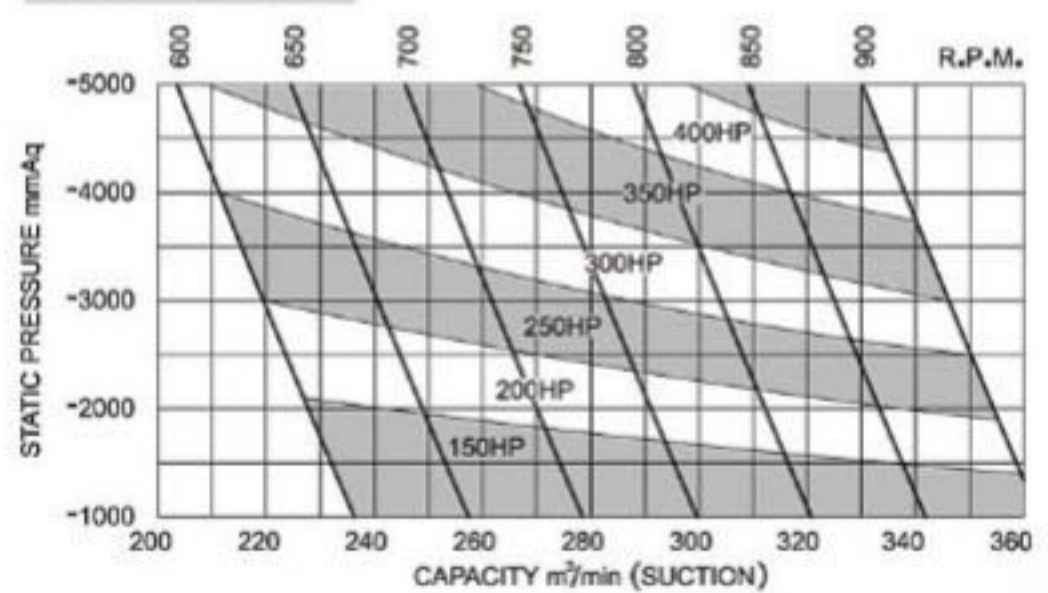

NOISE LEVEL OF BLOWER

◆ NOISE LEVEL MEASURED AT DISTANCE 1 METER FOR THE BLOWER FITTED WITH STANDARD SILENCER.

◆ NOISE LEVEL MAYBE DIFFERENT ACCORDING TO THE EXTEND PIPE LENGTH AND AMBIENT CONDITION.

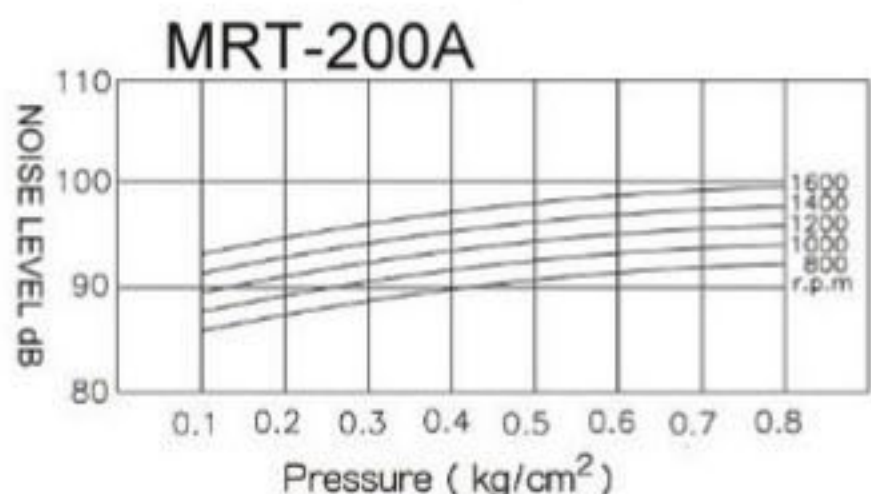
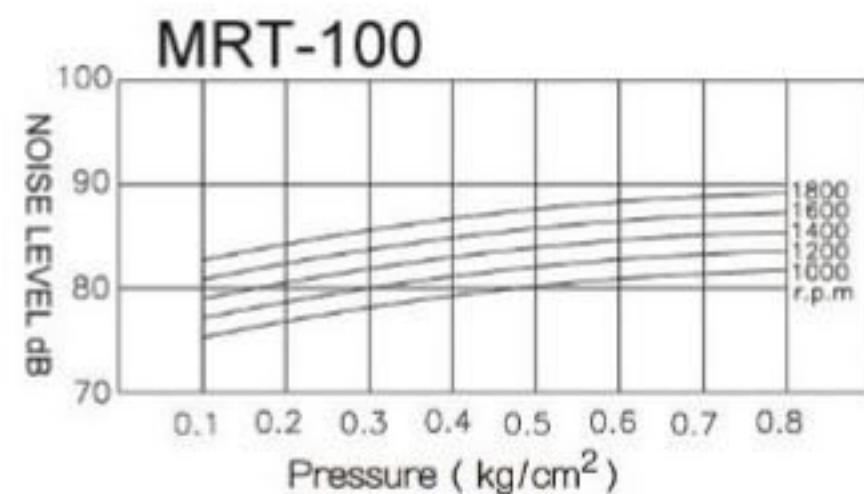
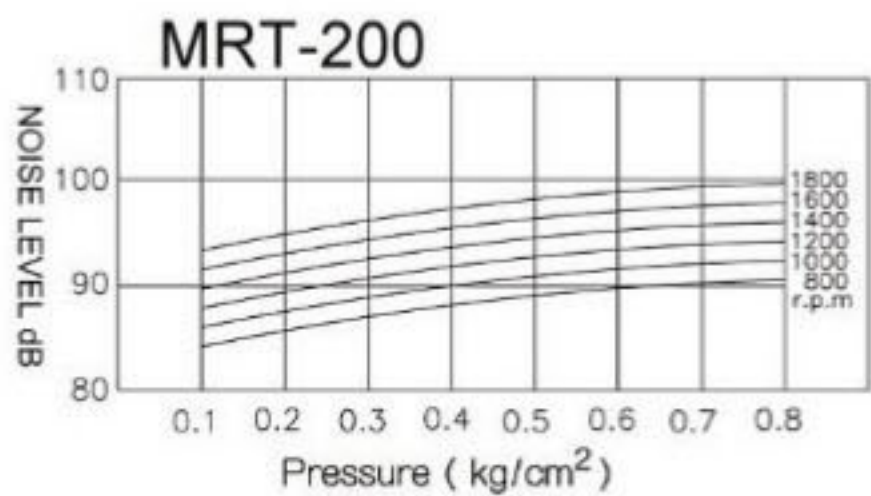
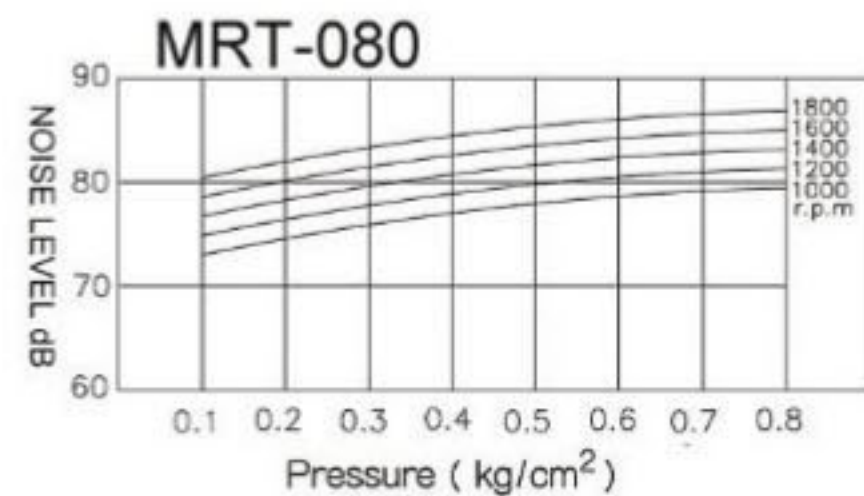
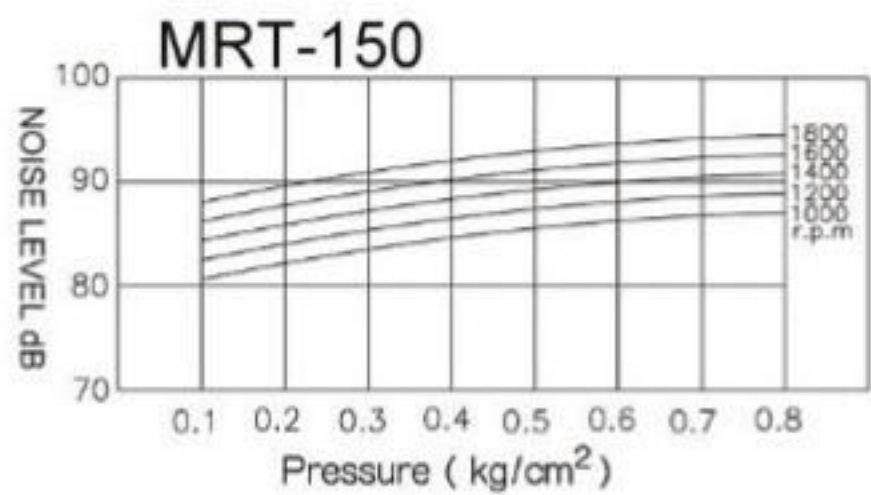
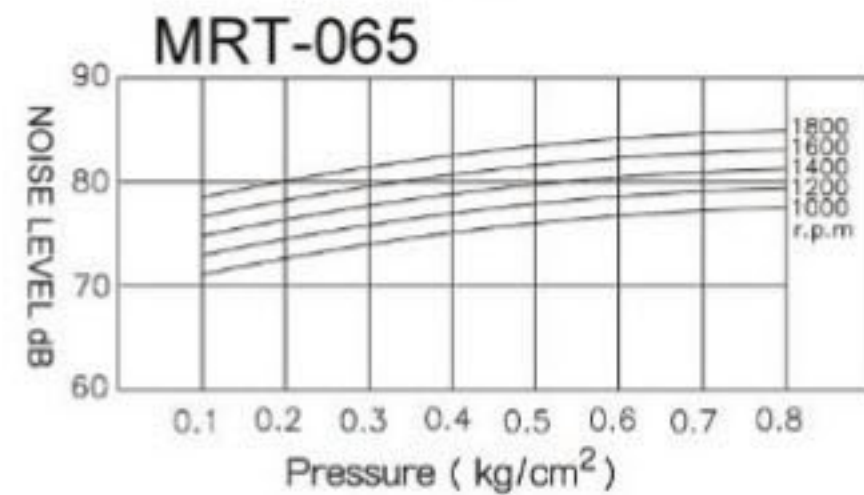
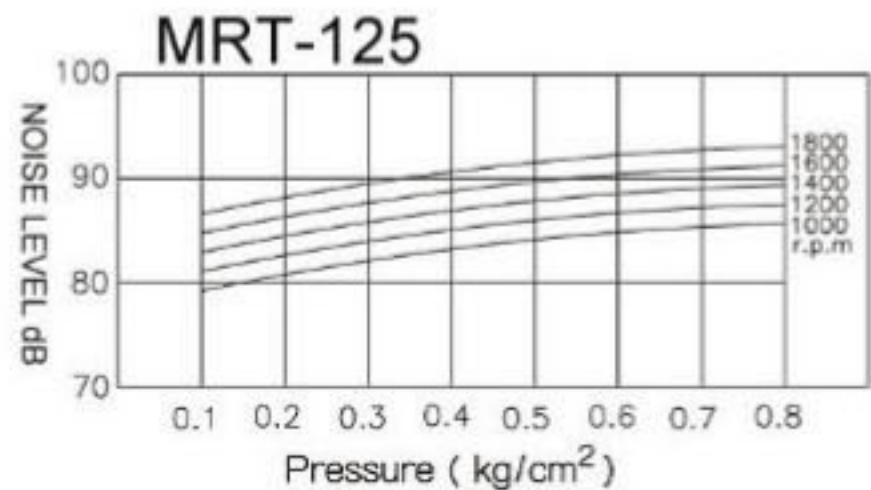
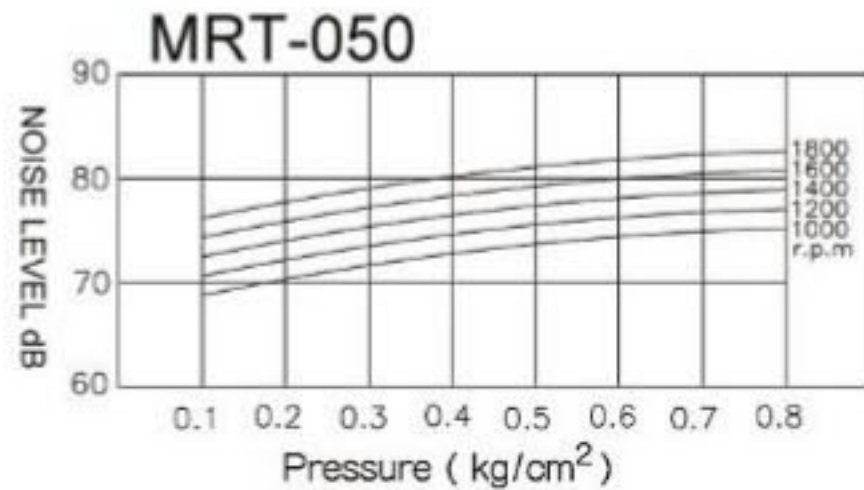
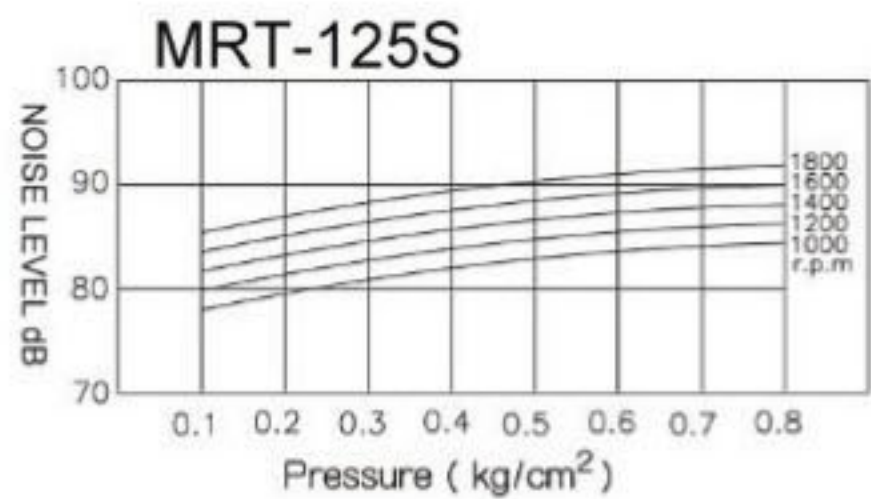
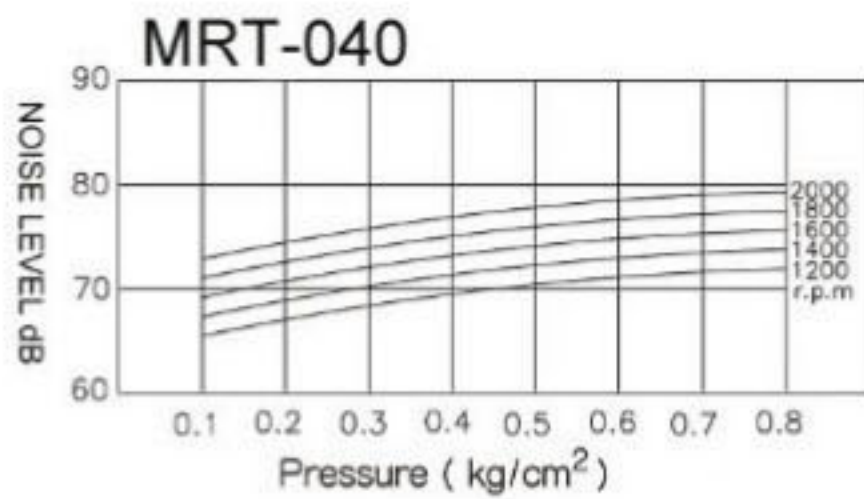

NOISE LEVEL OF BLOWER

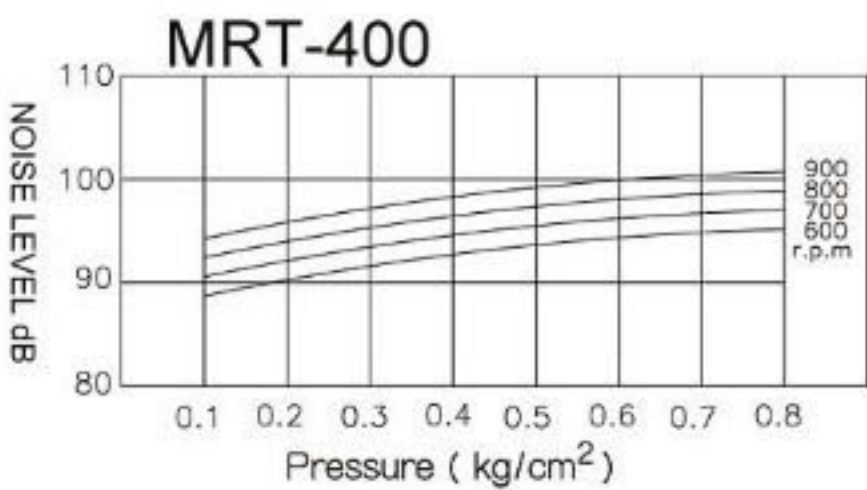
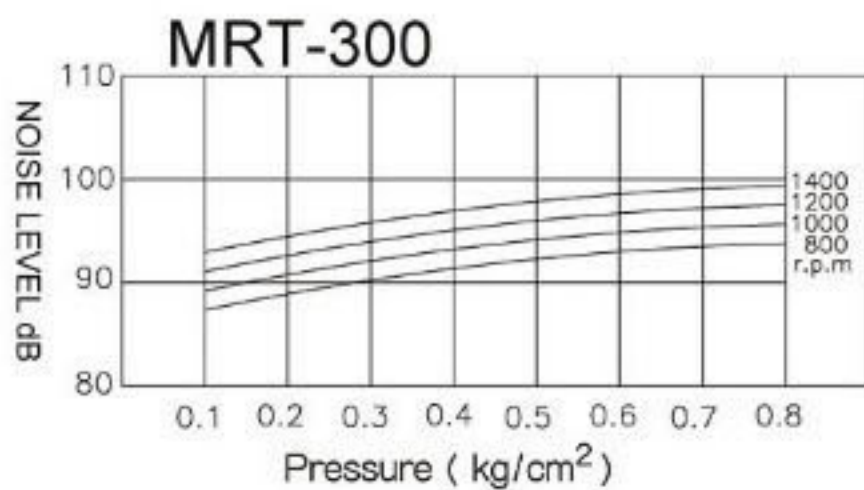
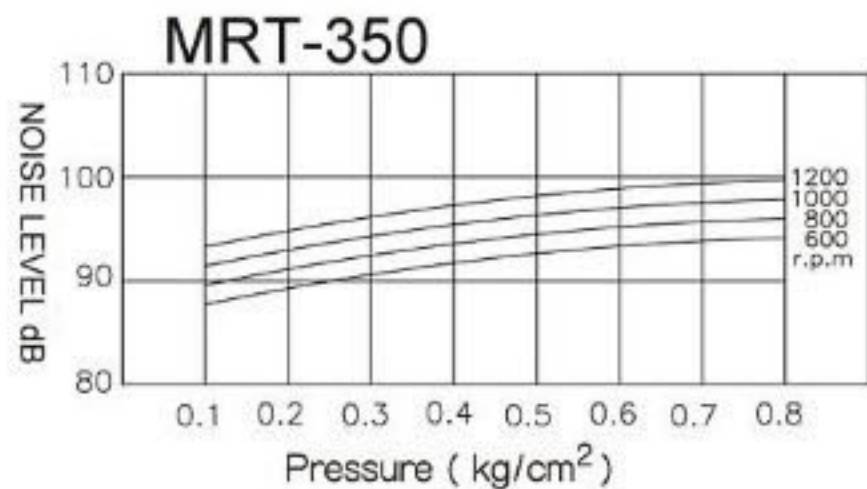
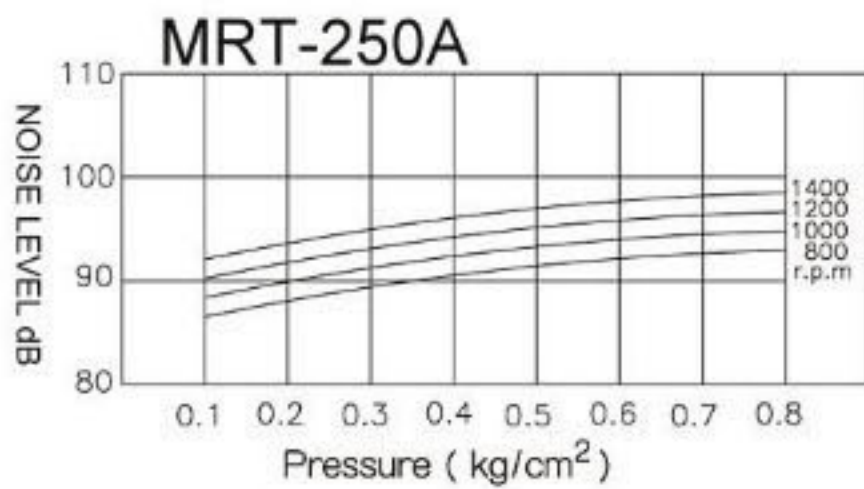
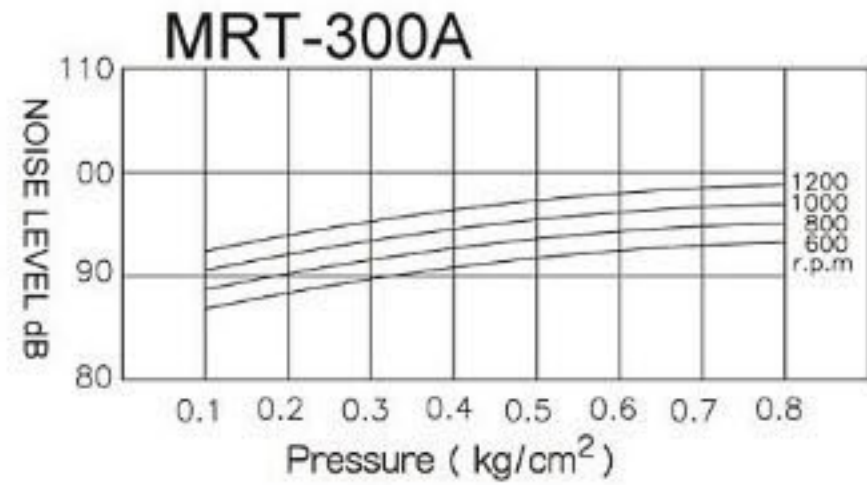
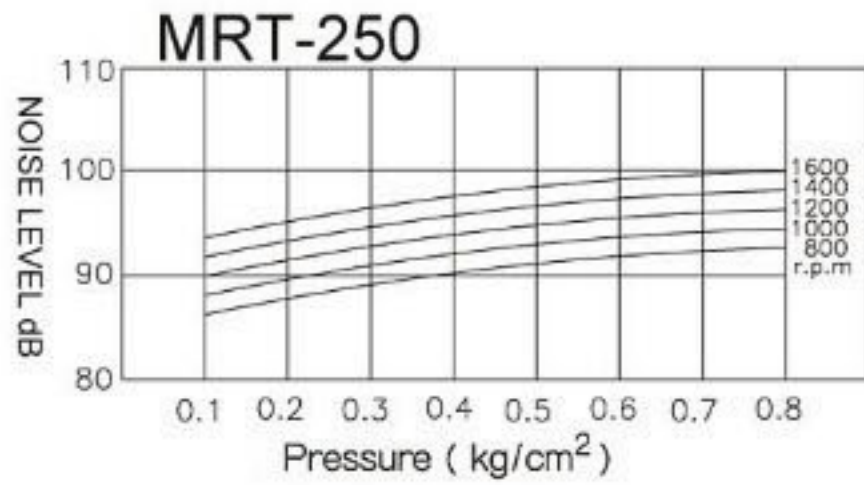

UNITS CONVERSION

PRESSURE

	mbar	Pa	atm	lbf/in ²	kgf/cm ²	in-Hg	mmAq
1 mbar	1	10 ²	9.869x10 ⁻⁴	1.45x10 ⁻²	1.02x10 ⁻³	2.953x10 ⁻²	10.197
1 Pa	0.01	1	9.869x10 ⁻⁶	1.45x10 ⁻⁴	1.02x10 ⁻⁵	2.953x10 ⁻⁴	0.102
1 atm	1.013x10 ³	1.013x10 ⁵	1	14.7	1.033	29.92	1.033x10 ⁴
1 lbf/in ²	68.95	6.895x10 ²	6.805x10 ⁻²	1	7.03x10 ⁻²	2.036	7.03x10 ²
1 kgf/cm ²	9.807x10 ²	9.807x10 ⁴	0.968	14.22	1	28.96	10 ⁴
1 in-Hg	33.86	3.386x10 ³	3.342x10 ⁻²	0.491	3.45x10 ⁻²	1	3.45x10 ²
1 mmAq	9.807x10 ⁻²	9.807	9.677x10 ⁻⁵	1.42x10 ⁻³	10 ⁻⁴	2.896x10 ⁻³	1

CAPACITY

	m ³ /min	m ³ /hr	l/min	ft ³ /min
1 m ³ /min	1	60	1000	35.31
1 m ³ /hr	0.017	1	16.67	0.589
1 l/min	0.001	0.06	1	0.035
1 ft ³ /min	0.028	1.699	28.32	1

POWER

	kg-m/sec	kW	HP	PS
1 kg-m/sec	1	0.01	0.013	0.013
1 kW	101.97	1	1.341	1.360
1 HP	76.038	0.746	1	1.014
1 PS	75	0.736	0.986	1

OUTLINE DIMENSION

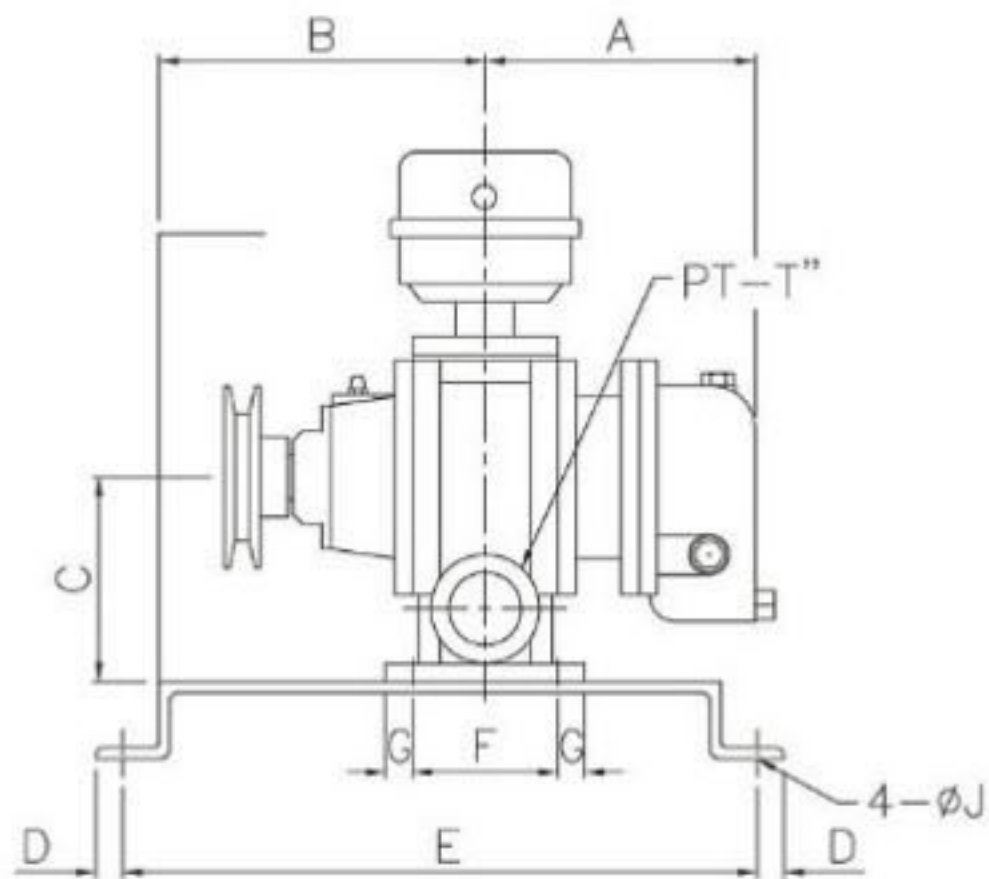

MRT-025~040

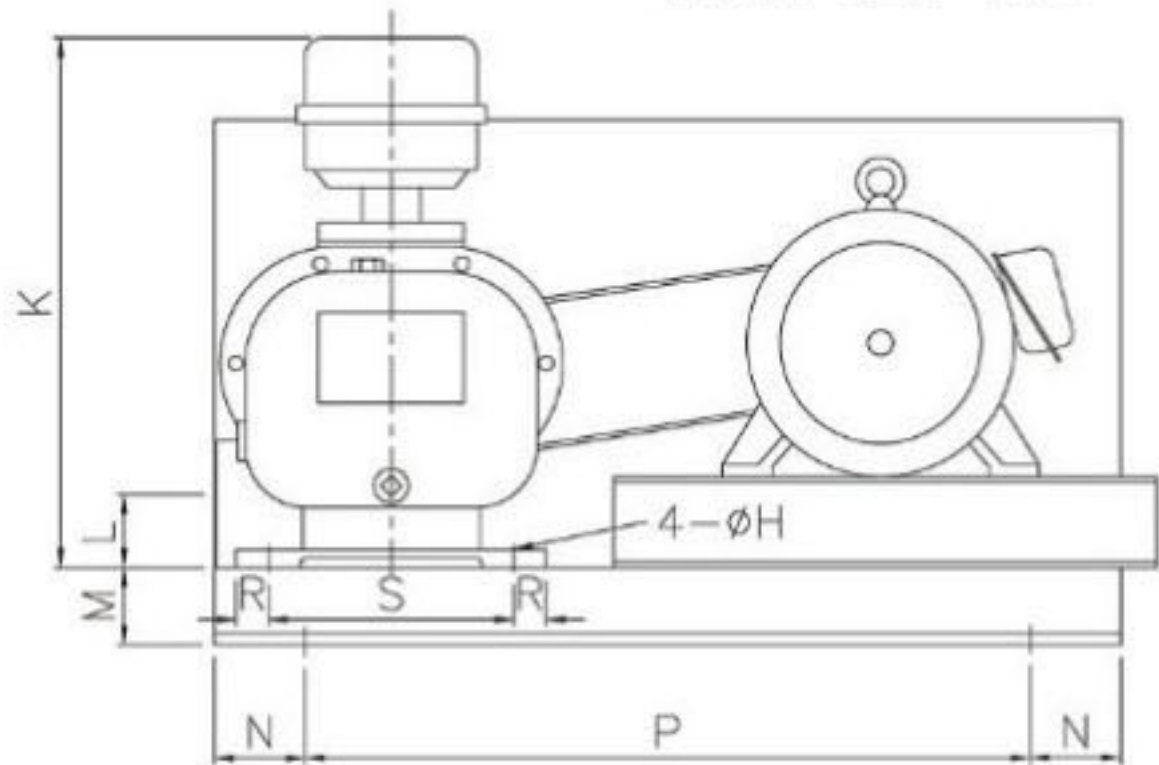

UNITS : mm

MODEL	A	B	C	D	E	F	G	H	J	K	L	M	N	P	R	S	T	Wt. (Kg)
MRT-025	135	145	120	15	350	54	13	10	12	340	40	43	50	400	15	135	1	20
MRT-040	162	185	120	15	350	80	15	10	12	340	40	43	50	400	15	135	1.5	25

◆ WT. FOR MAINBODY.

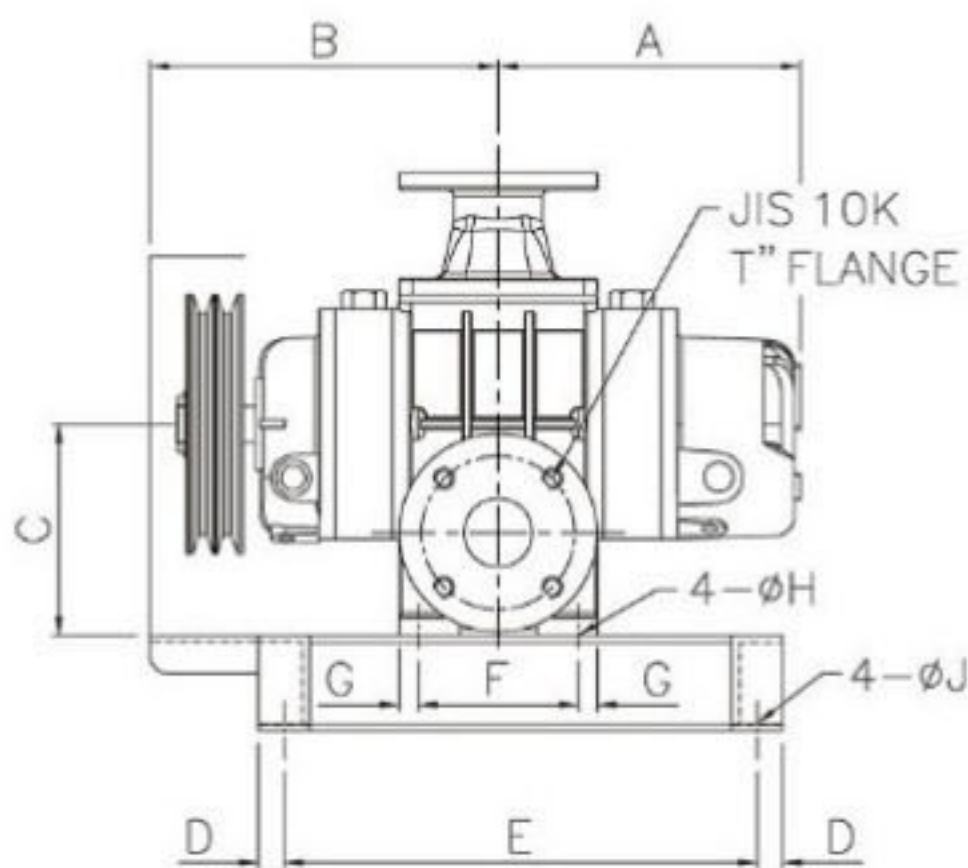

MRT-050~065

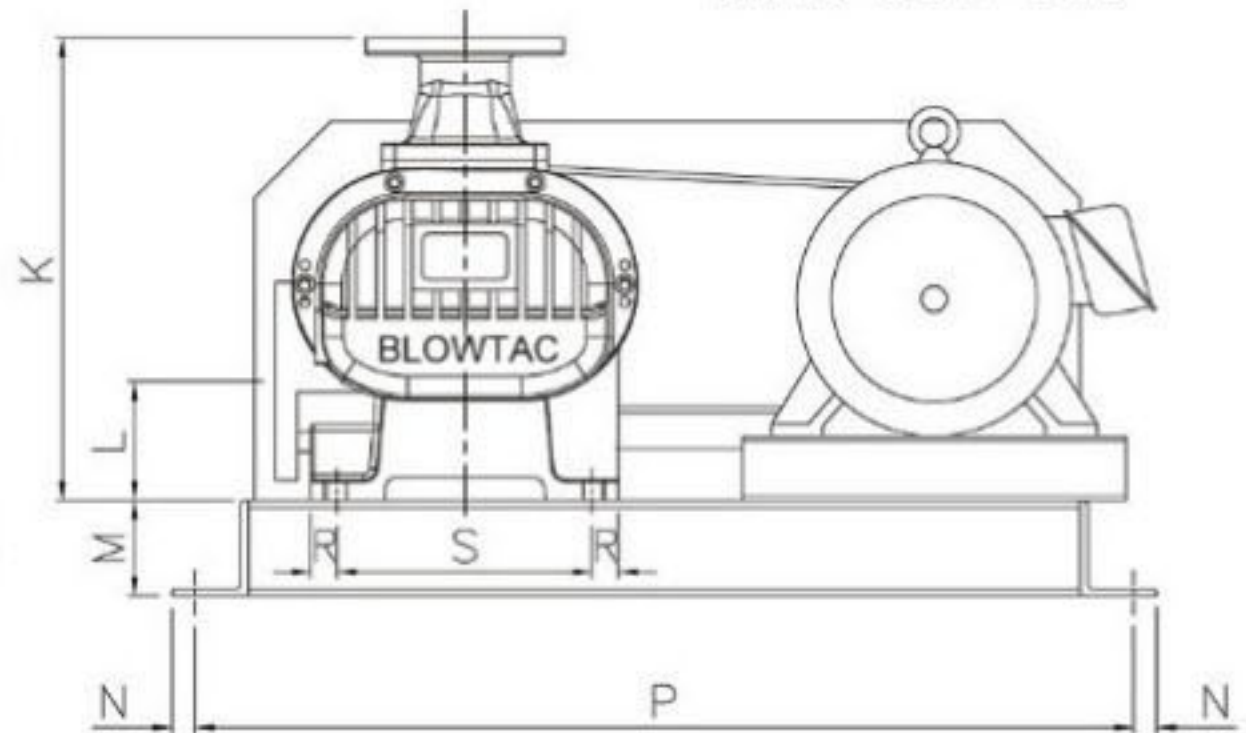

UNITS : mm

MODEL	A	B	C	D	E	F	G	H	J	K	L	M	N	P	R	S	T	Wt. (Kg)
MRT-050	240	270	168	20	370	125	15	15	15	356	90	75	18	734	15	200	2	76
MRT-065	280	290	173	20	370	210	15	15	15	356	95	75	18	734	15	200	2.5	94

◆ WT. FOR MAINBODY.

OUTLINE DIMENSION

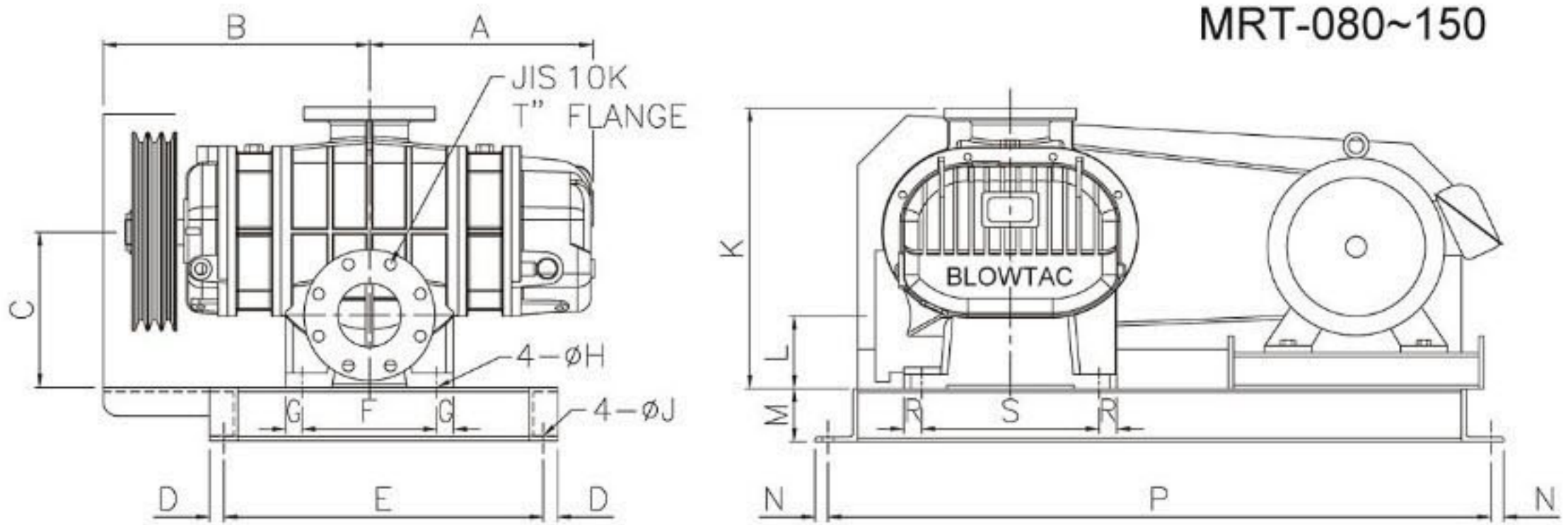

UNITS : mm

MODEL	A	B	C	D	E	F	G	H	J	K	L	M	N	P	R	S	T	Wt. (Kg)
MRT-080	315	375	220	20	450	190	25	19	15	395	102	75	18	934	25	250	3	167
MRT-100	365	425	220	20	450	290	25	19	15	395	115	75	18	934	25	250	4	193
MRT-125S	405	445	265	25	605	230	25	19	19	475	145	100	20	1190	25	350	5	319
MRT-125	445	485	300	25	605	320	25	19	19	515	155	100	20	1190	25	350	5	353
MRT-150	500	540	300	25	605	425	25	19	19	515	155	100	20	1190	25	350	6	418

◆ WT. FOR MAINBODY.

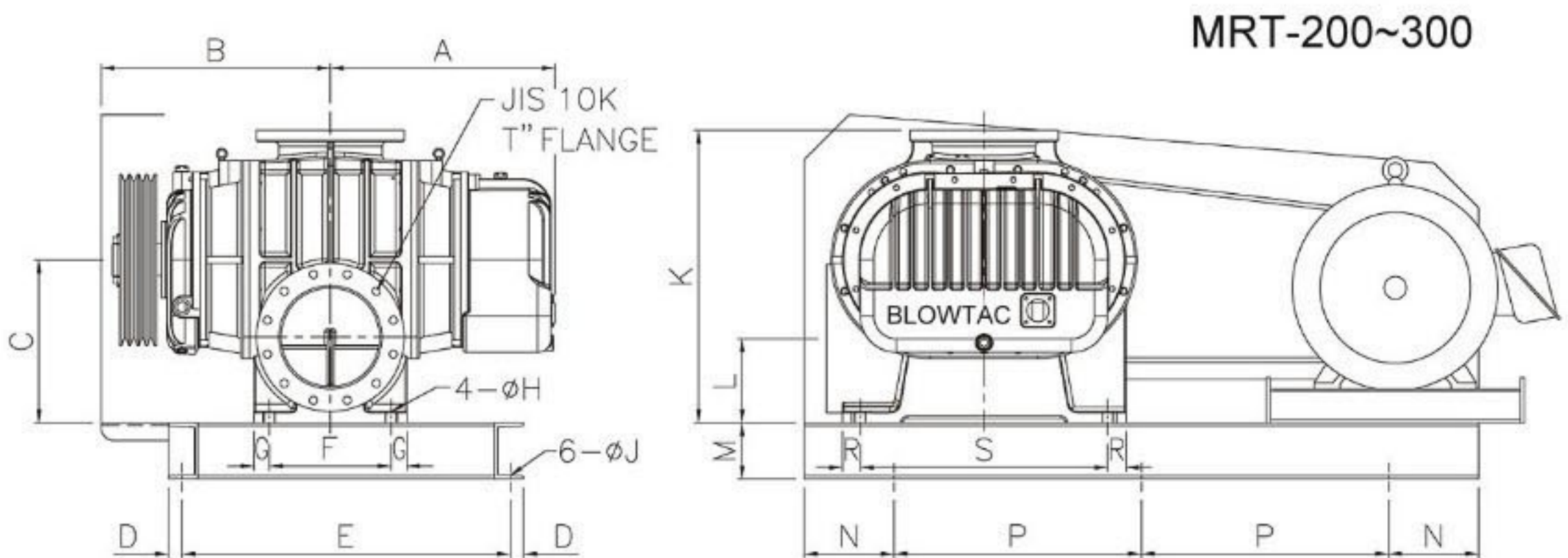

UNITS : mm

MODEL	A	B	C	D	E	F	G	H	J	K	L	M	N	P	R	S	T	Wt. (Kg)
MRT-200	515	495	363	30	730	270	35	23	19	650	190	125	200	550	40	550	8	720
MRT-200A	605	595	363	30	730	460	35	23	19	665	190	125	200	550	40	550	8	897
MRT-250	605	595	388	30	730	460	35	23	19	675	225	125	200	550	40	550	10	913
MRT-250A	778	678	500	40	850	650	65	27	24	875	250	200	200	800	55	620	10	1665
MRT-300	900	805	500	40	1120	650	65	27	24	875	250	200	200	800	55	620	12	2010
MRT-300A	954	840	505	40	1300	660	60	27	24	930	243	200	200	800	60	680	12	3200

◆ WT. FOR MAINBODY.

OUTLINE DIMENSION

MRT-350

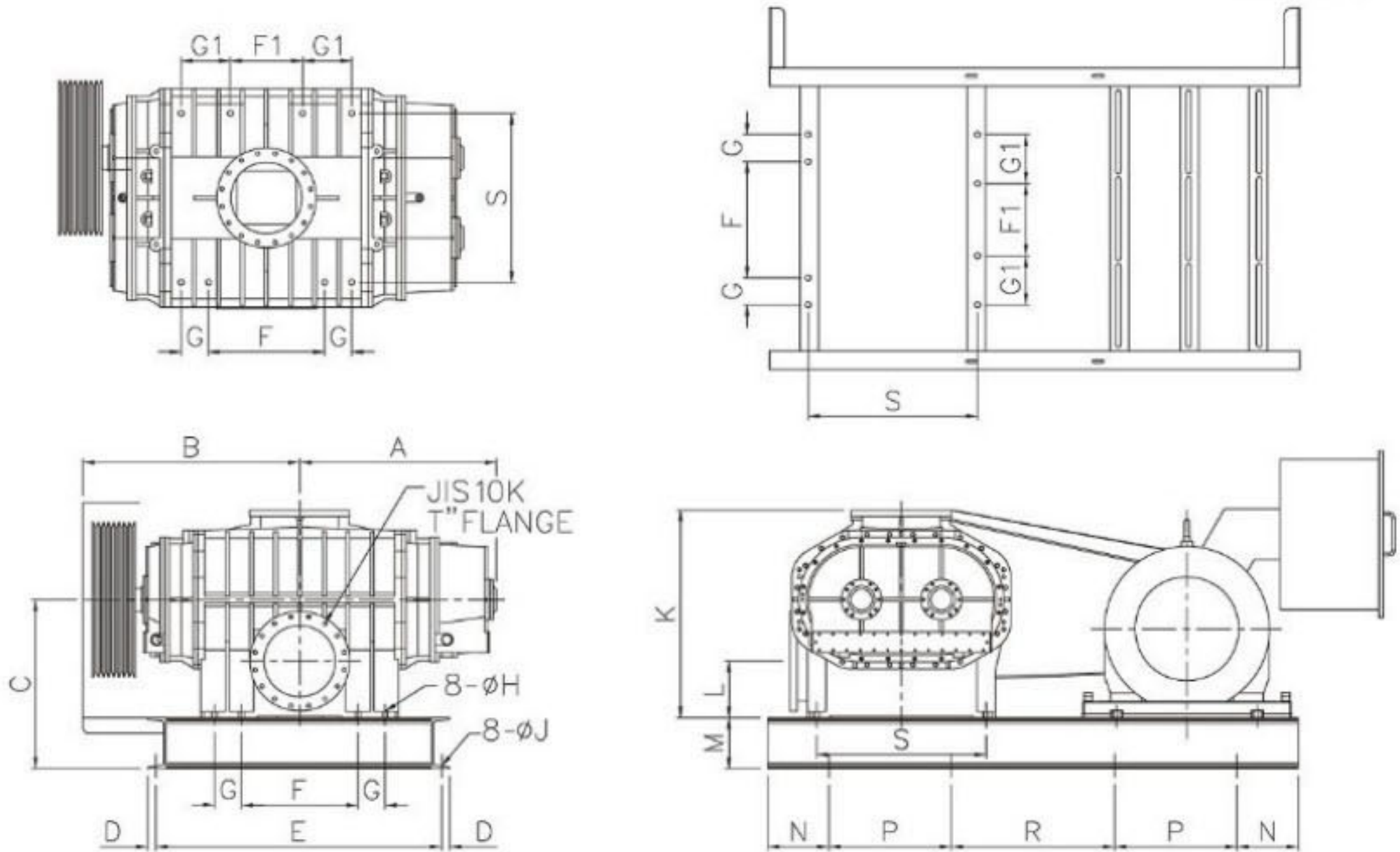

UNITS : mm

MODEL	A	B	C	D	E	F	F1	G	G1	H	J	K	L	M	N	P	R	S	T	Wt. (Kg)
MRT-350	965	1065	830	40	1400	570	354	133	35	241	24	1020	278	250	300	600	800	830	14	4100

◆ WT. FOR MAINBODY.

MRT-400

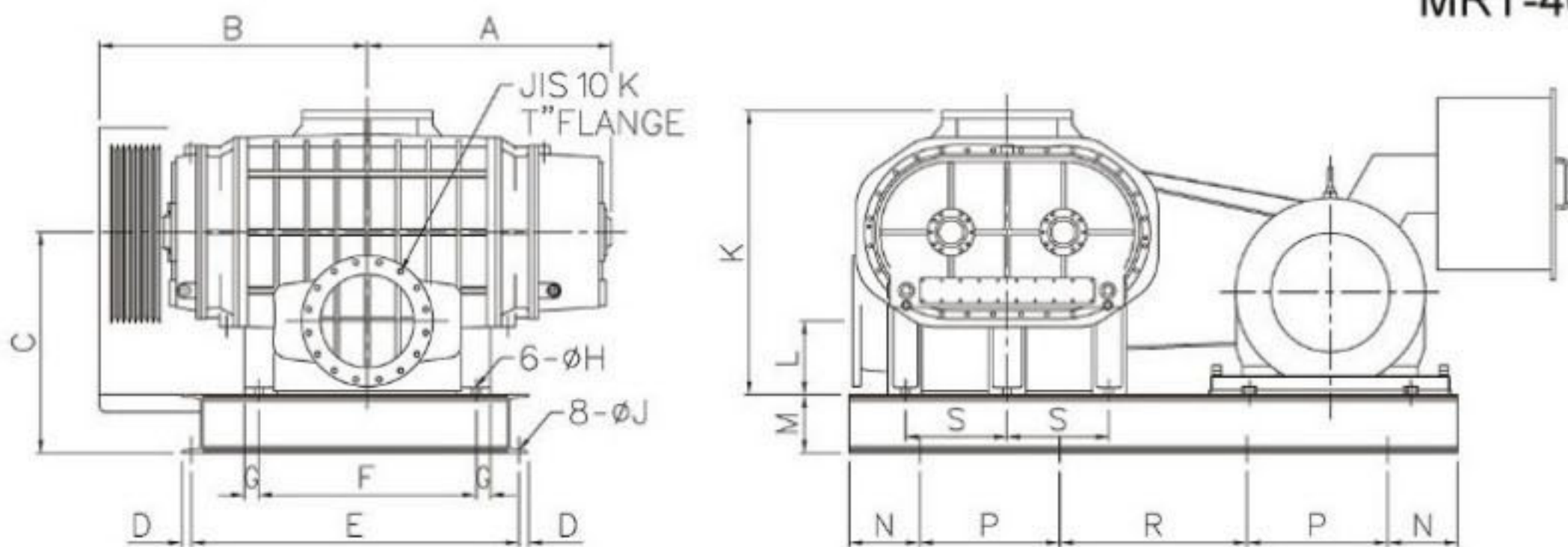

UNITS : mm

MODEL	A	B	C	D	E	F	G	H	J	K	L	M	N	P	R	S	T	Wt. (Kg)
MRT-400	1043	1147	945	40	1400	930	60	35	24	1215	315	250	300	600	800	435	16	4650

◆ WT. FOR MAINBODY.



INDUSTRIAL TECH SOLUTIONS

STRUCTURE & MATERIAL LIST

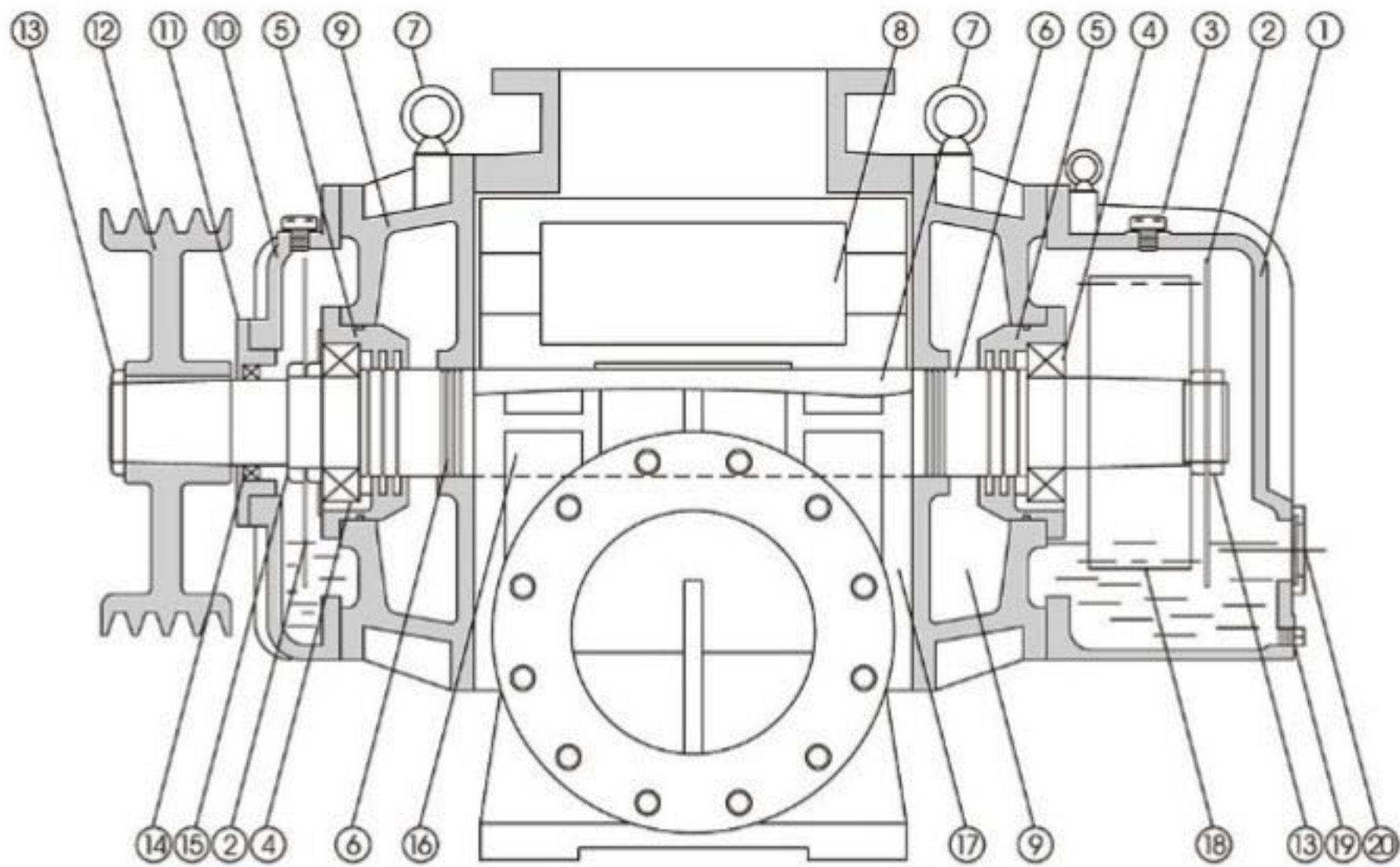

NO.	NAME	MATERIAL	NO.	NAME	MATERIAL
1.	Gear case	FC250	11.	Seal case	FC250
2.	Oil splash	SS400	12.	Pulley	FC250
3.	Oil plug	S45C	13.	Nut	SS400
4.	Bearing	SUJ2	14.	Seal	NBR
5.	Bearing case	FC250	15.	Nut	SS400
6.	Labyrinth seal	SS400	16.	Shaft	SCM440
7.	Eye bolt	S45C	17.	Main casing	FC250
8.	Rotor	FC250	18.	Timing gear	SCM415
9.	Side cover	FC250	19.	Oil drain	S45C
10.	Oil case	FC250	20.	Oil gauge	S45C

INSTALLATIONS

A. FOR PRESSURE

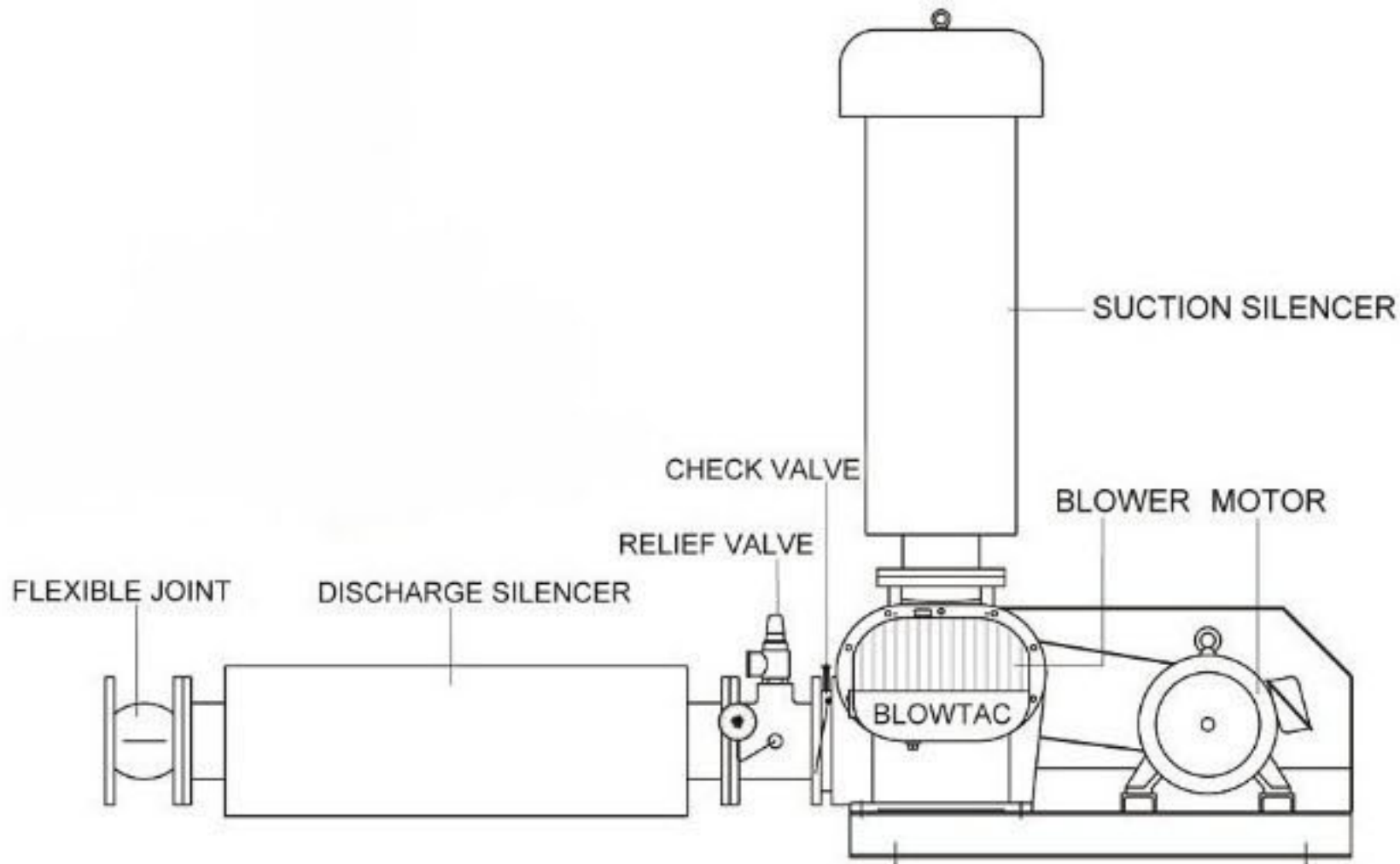

B. FOR VACUUM

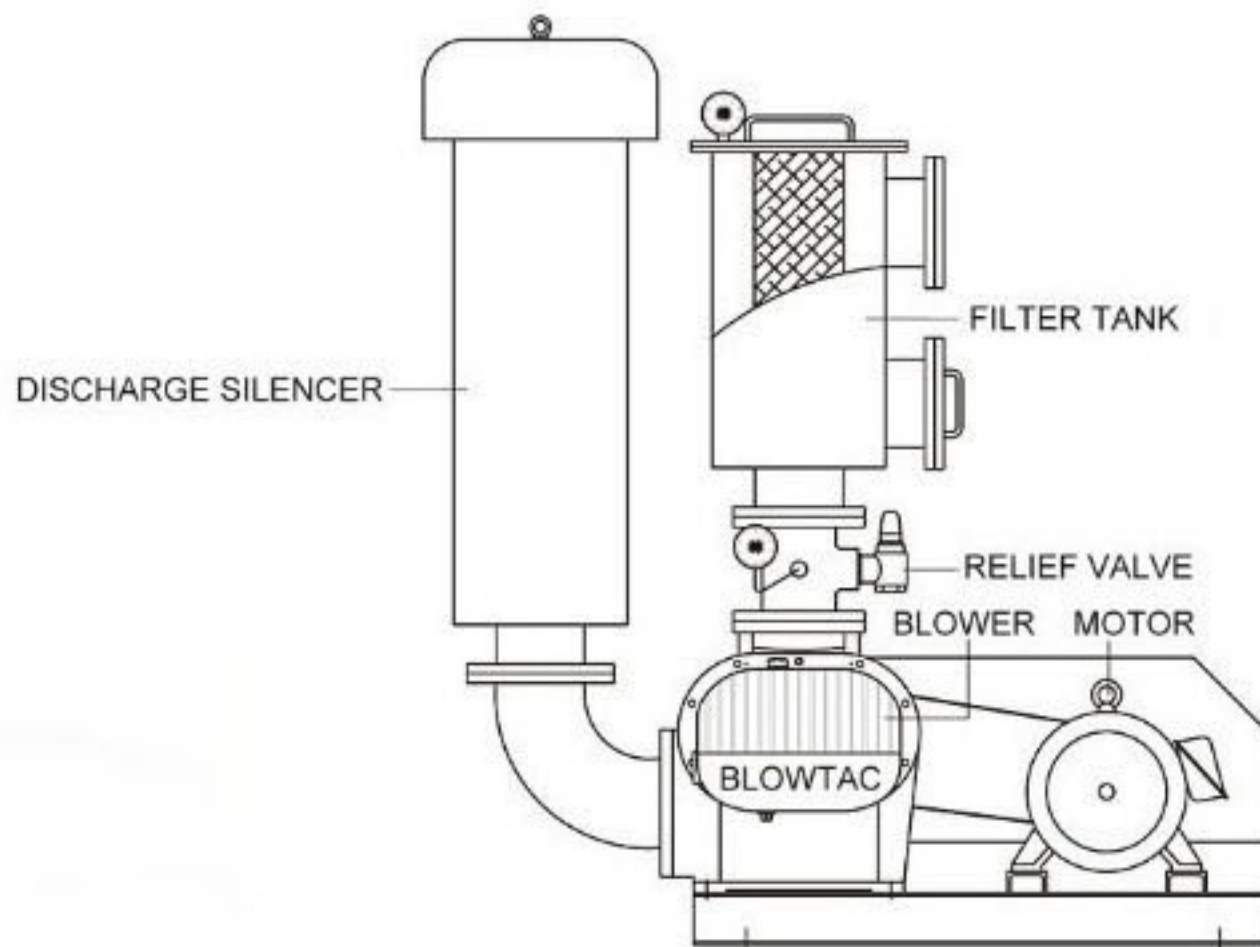

ACCESSORIES

OUTDOOR SILENCER

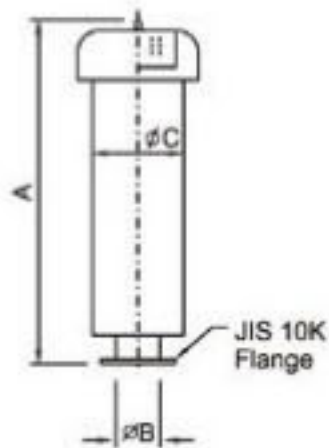

UNITS : mm

MODEL	A	B	C	MODEL
O-050	680	50	165	MRT-050
O-065	680	65	165	MRT-065
O-080	800	80	216	MRT-080
O-100	820	100	267	MRT-100
O-125	1300	125	350	MRT-125
O-150	1300	150	350	MRT-150
O-200	2030	200	525	MRT-200
O-250	2030	250	600	MRT-250
O-300	2240	300	700	MRT-300
O-350	2570	350	800	MRT-350
O-400	2570	400	800	MRT-400

INDOOR SILENCER

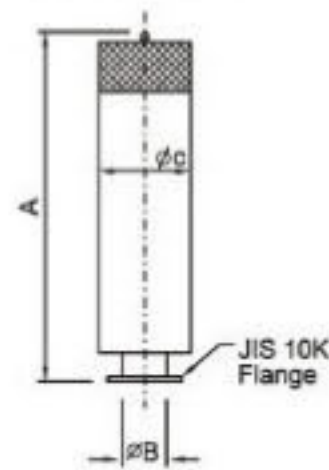

UNITS : mm

MODEL	A	B	C	MODEL
I-050	680	50	165	MRT-050
I-065	680	65	165	MRT-065
I-080	800	80	216	MRT-080
I-100	820	100	267	MRT-100
I-125	1300	125	350	MRT-125
I-150	1300	150	350	MRT-150
I-200	2030	200	525	MRT-200
I-250	2030	250	600	MRT-250
I-300	2240	300	700	MRT-300
I-350	2570	350	800	MRT-350
I-400	2570	400	800	MRT-400

DISCHARGE SILENCER

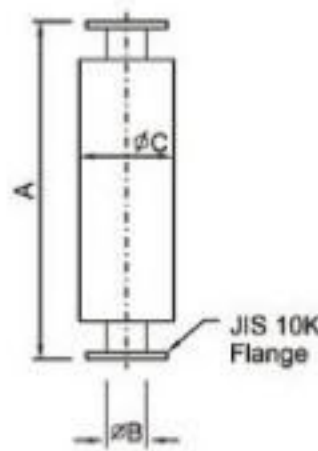

UNITS : mm

MODEL	A	B	C	MODEL
D-050	660	50	165	MRT-050
D-065	660	65	165	MRT-065
D-080	760	80	216	MRT-080
D-100	760	100	267	MRT-100
D-125	1190	125	350	MRT-125
D-150	1190	150	350	MRT-150
D-200	1735	200	525	MRT-200
D-250	1735	250	600	MRT-250
D-300	1735	300	700	MRT-300
D-350	2230	350	800	MRT-350
D-400	2230	400	800	MRT-400

HORIZONTAL SILENCER

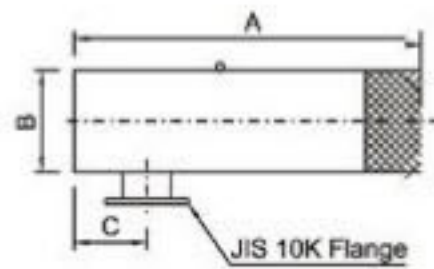

UNITS : mm

MODEL	A	B	C	MODEL
RO-050	580	165	120	MRT-050
RO-065	580	165	120	MRT-065
RO-080	700	216	150	MRT-080
RO-100	700	267	150	MRT-100
RO-125	1200	350	150	MRT-125
RO-150	1200	350	150	MRT-150
RO-200	1880	525	400	MRT-200
RO-250	1880	600	400	MRT-250
RO-300	2090	700	400	MRT-300
RO-350	2420	800	400	MRT-350
RO-400	2420	800	400	MRT-400

T-JOINT

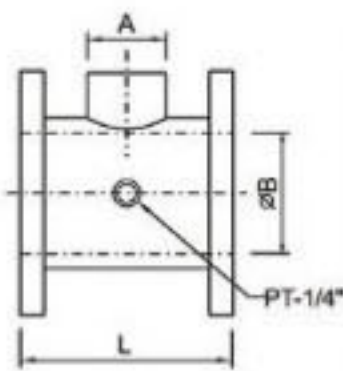

UNITS : mm

MODEL	A	B	C	MODEL
T-050	40	50	150	MRT-050
T-065	40	65	150	MRT-065
T-080	40	80	165	MRT-080
T-100	40	100	165	MRT-100
T-125	50	125	205	MRT-125
T-150	50	150	210	MRT-150
T-200	50	200	265	MRT-200

T-JOINT

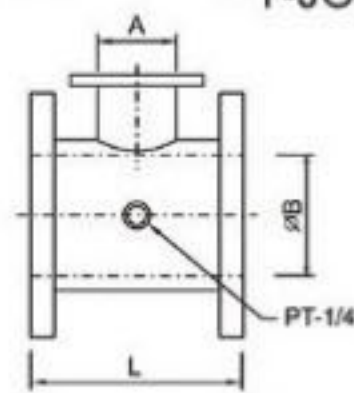

UNITS : mm

MODEL	A	B	L	MODEL
T-250	80	250	295	MRT-250
T-300	80	300	350	MRT-300
T-350	125	350	400	MRT-350
T-400	125	400	500	MRT-400

RELIEF VALVE

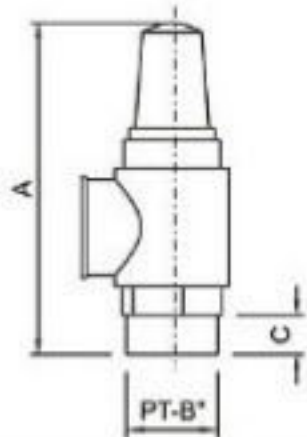

UNITS : mm

MODEL	A	B	C	MODEL
R-038	132	1.5"	26	MRT-050~100
R-050	150	2"	28	MRT-125~200

RELIEF VALVE

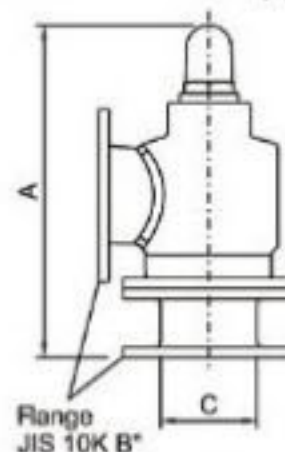

UNITS : mm

MODEL	A	B	C	MODEL
R-080	485	3"	80	MRT-250~300
R-125	485	5"	125	MRT-350~400

FLEXIBLE JOINT

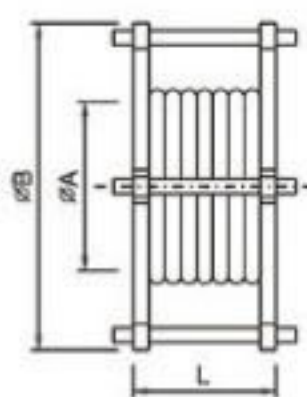

UNITS : mm

MODEL	A	B	L	MODEL
JF-050	50	155	150	MRT-050
JF-065	65	175	150	MRT-065
JF-080	80	185	150	MRT-080
JF-100	100	210	150	MRT-100
JF-125	125	250	150	MRT-125
JF-150	150	280	150	MRT-150
JF-200	200	330	200	MRT-200
JF-250	250	400	200	MRT-250
JF-300	300	445	200	MRT-300
JF-350	350	490	230	MRT-350
JF-400	400	560	250	MRT-400

FLEXIBLE JOINT

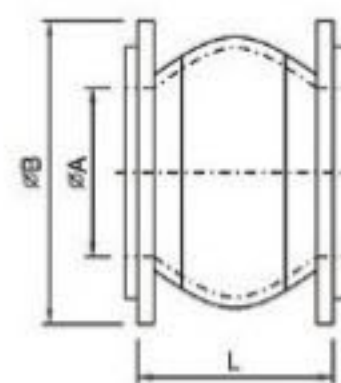

UNITS : mm

MODEL	A	B	L	MODEL
F-050	50	155	105	MRT-050
F-065	65	175	115	MRT-065
F-080	80	185	130	MRT-080
F-100	100	210	135	MRT-100
F-125	125	250	170	MRT-125
F-150	150	280	180	MRT-150
F-200	200	330	205	MRT-200
F-250	250	400	240	MRT-250
F-300	300	445	260	MRT-300
F-350	350	490	265	MRT-350
F-400	400	560	265	MRT-400

ACCESSORIES

SUCTION SHORT SILENCER

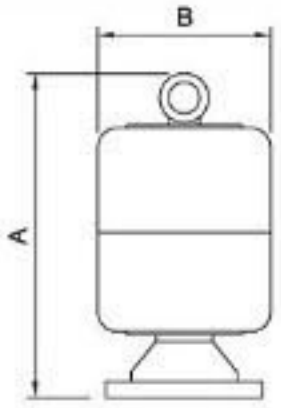

UNITS : mm

MODEL	A	B	MODEL
S-50	320	176	MRT-050
S-65	320	176	MRT-065

90° ELBOW

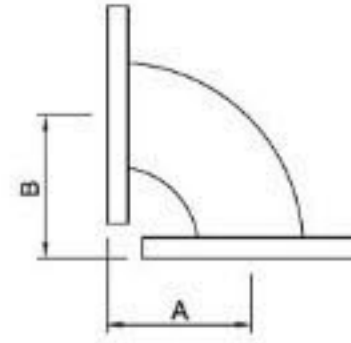

UNITS : mm

MODEL	A	B	MODEL
HE-050	83	121	MRT-050
HE-065	103	103	MRT-065
HE-080	122	122	MRT-080
HE-100	160	160	MRT-100
HE-125	199	199	MRT-125
HE-150	237	237	MRT-150
HE-200	313	313	MRT-200
HE-250	389	389	MRT-250
HE-300	465	465	MRT-300
HE-350	541	541	MRT-350
HE-400	618	618	MRT-400

FILTER TANK

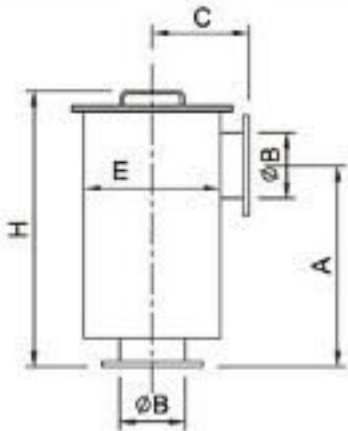

UNITS : mm

MODEL	A	B	C	E	H
B-050	395	50	180	210	530
B-065	395	65	180	210	530
B-080	480	80	210	270	670
B-100	480	100	210	270	670

FILTER TANK

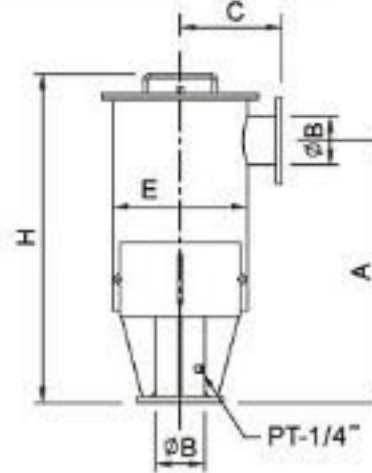

UNITS : mm

MODEL	A	B	C	E	H
B-125	760	125	270	330	770
B-150	760	150	270	330	770
B-200	920	200	370	492	1140
B-250	1092	250	358	492	1340
B-300	1200	300	420	612	1540
B-350	1300	350	515	777	1645
B-400	1300	400	515	777	1645

CHECK VALVE

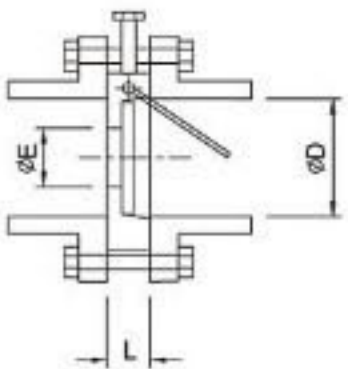

UNITS : mm

MODEL	D	E	L	MODEL
C-050	50	30	17	MRT-050
C-065	65	45	19	MRT-065
C-080	80	55	20	MRT-080
C-100	100	70	20	MRT-100
C-125	125	90	23	MRT-125
C-150	150	110	24	MRT-150
C-200	200	140	28	MRT-200
C-250	250	190	28	MRT-250

DUAL CHECK VALVE

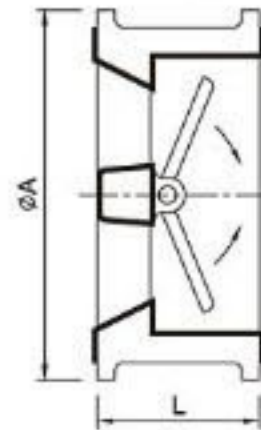

UNITS : mm

MODEL	A	L	MODEL
DC-200	270	127	MRT-200
DC-250	332	146	MRT-250
DC-300	377	181	MRT-300
DC-350	420	184	MRT-350
DC-400	483	191	MRT-400

LIQUID FILLED PRESSURE GAUGE

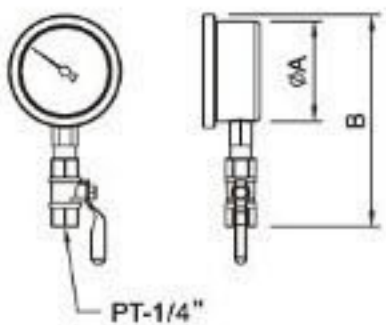

UNITS : mm

MODEL	A	B	MODEL
AC-A	63	133.5	MRT-50~400
P RANGE	76~0cmHg, 0~1kg/cm ²		

TUBE CONNECTOR

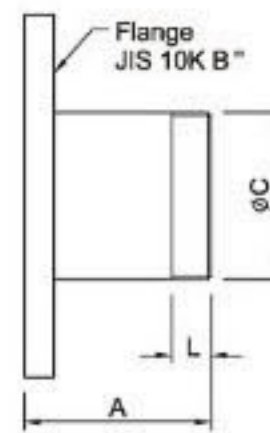

UNITS : mm

MODEL	A	B	C	L	MODEL
V-050	95	2"	50	40	MRT-050
V-065	95	2.5"	65	40	MRT-065
V-080	95	3"	80	40	MRT-080
V-100	95	4"	100	40	MRT-100
V-125	155	5"	125	50	MRT-125
V-150	155	6"	150	50	MRT-150
V-200	155	8"	200	60	MRT-200
V-250	155	10"	250	60	MRT-250
V-300	155	12"	300	60	MRT-300
V-350	160	14"	350	70	MRT-350
V-400	160	16"	400	70	MRT-400

ABSORBER

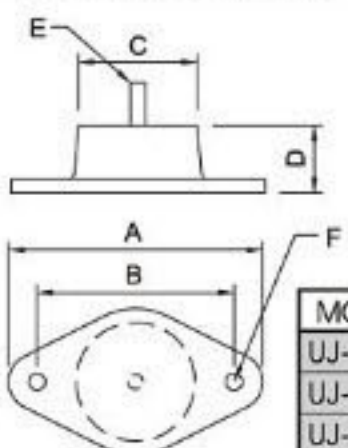

UNITS : mm

MODEL	A	B	C	D	E	F	SCOPE (kg)
UJ-200J	142	110	65	55	3/8"	ø12	0~150
UJ-500J	214	166	100	57	1/2"	ø14	140~450
UJ-800J	285	220	130	80	1/2"	ø17	400~750

ABSORBER

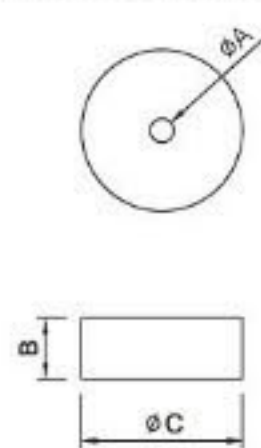

UNITS : mm

MODEL	A	B	C	D	E	F
MRT-040	15	25	50			
MRT-050~065	15	25	75			
MRT-080~100	25	39	102			
MRT-125~400				101	147	10

Side Channel Blower



INDUSTRIAL TECH SOLUTIONS

9/7 F, Second Stage, Gray Line Park, Ekala.

Tel : 94-11-2245689 Mobile : 0773 385 811

Fax : 94-11-2245689 Email : indtechlanka@gmail.com

SAVE A GREEN WORLD FOR TOMORROW